

Shingle:

Shingles (lat, takhte) are the flat boards used for roof covering.

Shingle roofs occur on the foothills basically within the forests (eg. Shanderman) and in the mountains (eg. Kodir, mountain village south of Alamdeh; or Chajkam in the mountains south of Sari). Previously when there was no control on the felling of trees, the use of shingles was more common. Since the introduction of control by the Forestry Department tree cutting requires their permission. This has acted as a restriction on this type of roofing. In many areas people rely on finding trees that have already fallen down, which is rare and results in poorer quality timber. Good quality shingles last ten to fifteen years. During this period they are usually turned over once, after five years (approximately) to expose the underside of the shingle and hence prolong its life.

Shingles are normally 50 to 60 cm. long; the width varies from 15 to 30 cm. depending on the width of the log from which the shingle comes. They are 2 to 3 cm. thick. Oak is the most common tree used. The log is cut into lengths of 50 to 60 cm. To produce the best shingles an axe is used to split the wood along the grain (b). If the grain is cut, as shown in (a) ready channels are provided for the water to work its way through from the outer to the inner surface of the board; the use of a saw produces this effect and sawn shingles are rarely seen (some were noted near to the sawmills around Asalem).

In Gilan and the western end of Mazandaran (Kodir) the shingles are laid on horizontal battens at approximately 30 cm. centres. Each shingle is laid to overlap the joint of the two shingles below it. Individual boards are held in place by their own

SHINGLES

Approximate dimensions

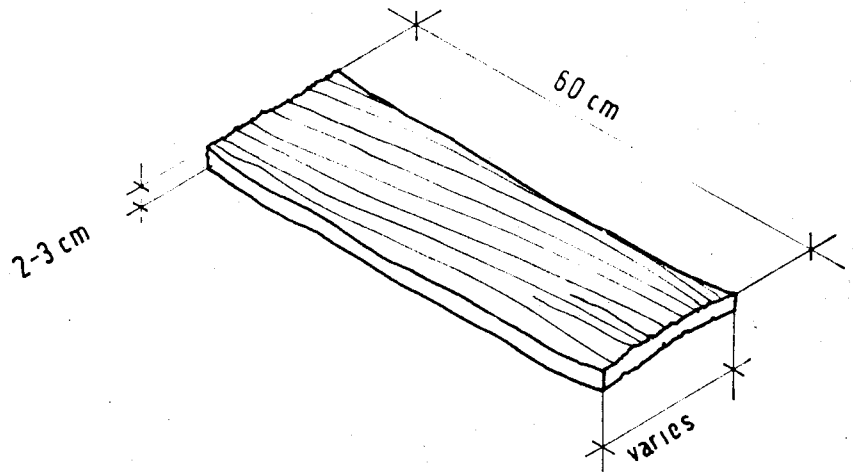

a. sawn wood cuts the cell structure allowing water to penetrate (c)

b. split wood follows the grain and leaves the cells intact

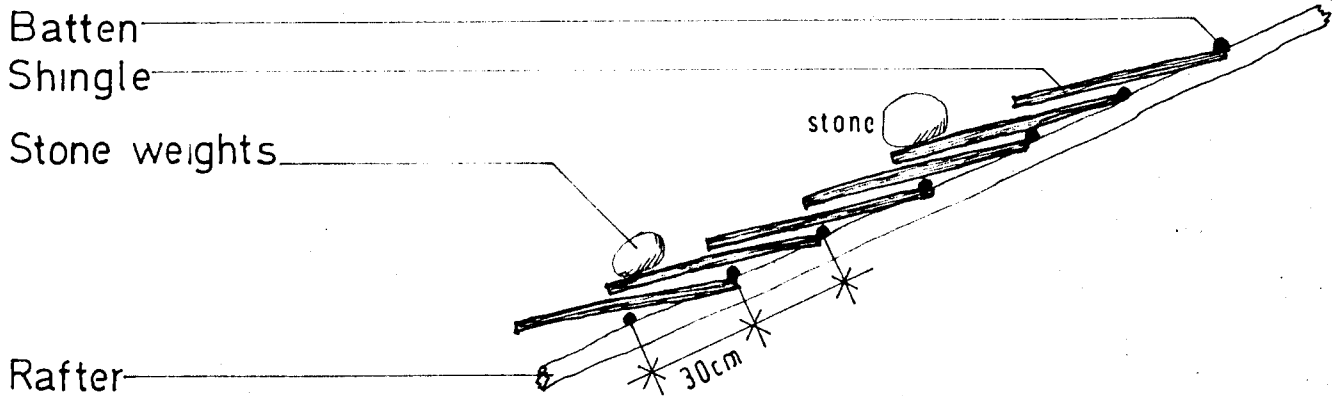
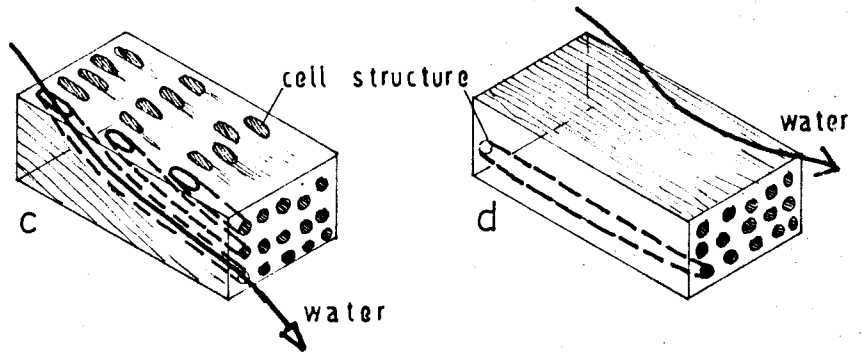
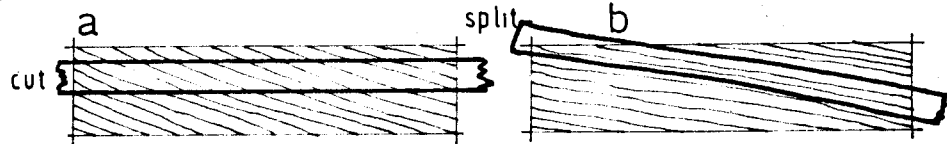

Upper shingles overlap gaps between shingles below

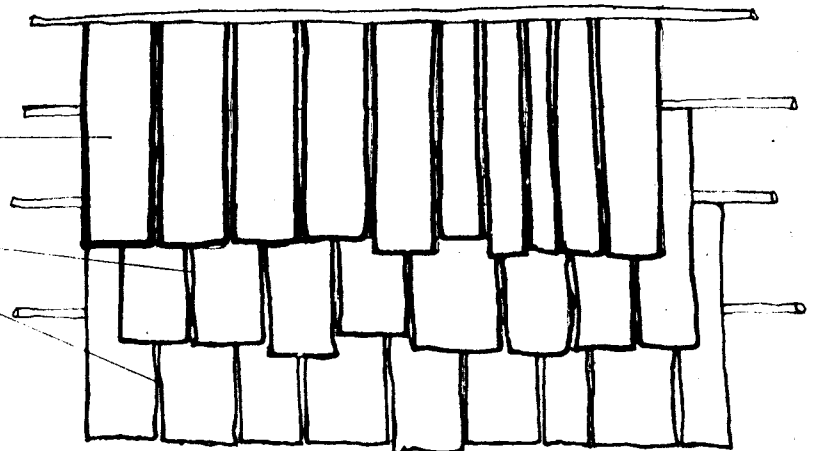

weight and the pressure of the board above it. Stones are also used to provide more weight, especially along the ridges and eaves.

Two people can prepare 1000 shingles in a day. When laying shingles on the roof, two roofers and two assistant workers can roof three $3 \times 5 \text{ m}^2$ rooms in one day. Approximately 2500 shingles are required to roof one $3 \times 5 \text{ m}^2$ room. One large tree will provide sufficient shingles for a small two room house.

In the hills behind Sari (central Mazandaran) shingles are held in place by nails. These shingles are slightly larger than those in Gilan and are of the sawn kind. The effect on the roof is neater but the process is longer. In the more remote areas where sheet metal cannot be brought easily, shingles are still being used for re-roofing, but the limitations of cutting trees makes it increasingly difficult.

The lifespan of shingles could be improved by the use of wood preservatives for which some methods are suggested in the section on preservation of timber. Given the difficulties of replacing shingles, the added expense involved in preservation will probably be worthwhile and economical.



Wood shingles roof. Note stones for weighting down shingles.



External detail of shingle roof.



Internal detail of shingle roof with wooden battens.



Detail showing
overlap of shingles.

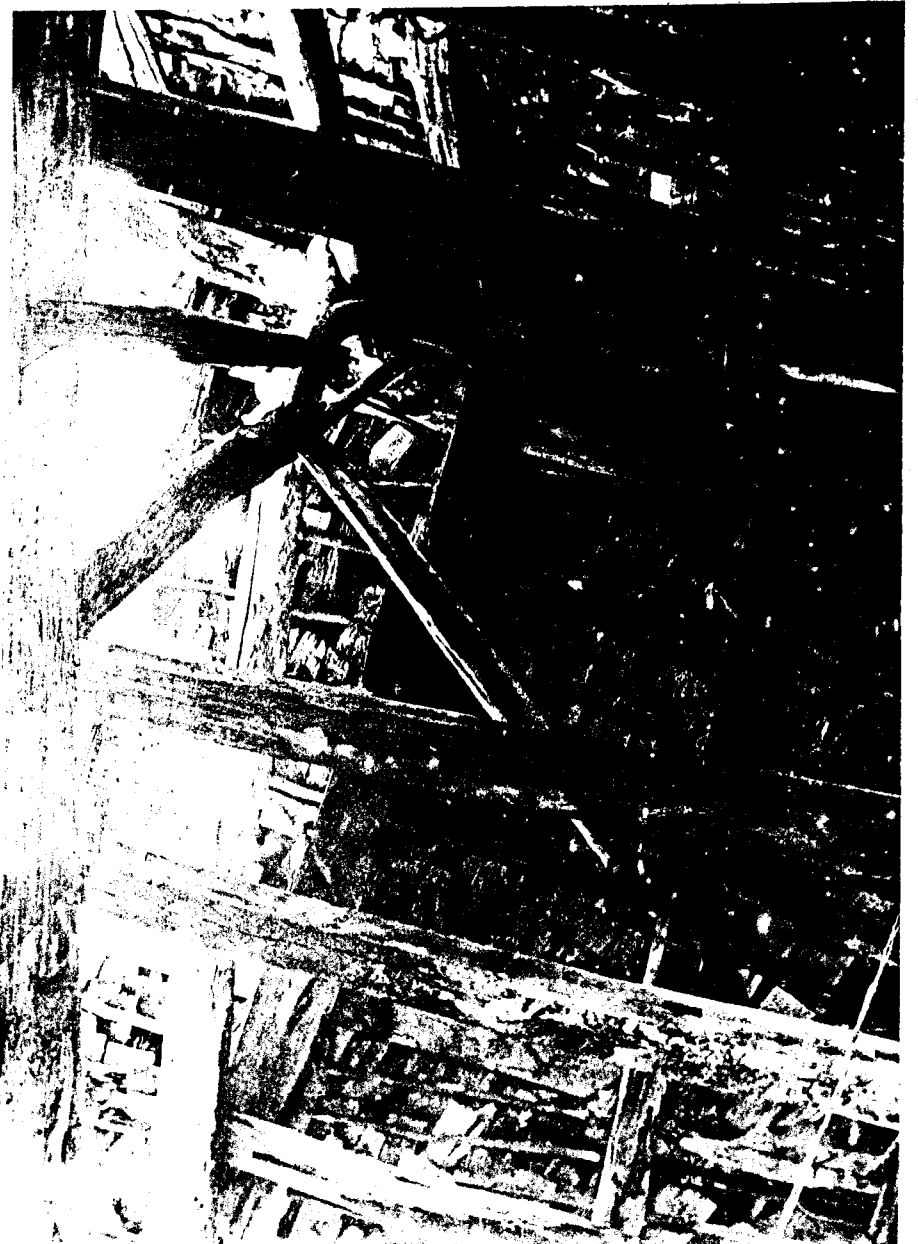

Interior of shingle
roof with supporting
frame work.



Corner detail of the underside of a shingle roof, with careful joinery.



The large overhang is typical of shingle roofs. Stone walls are plastered with mud.

Single Lap Tiles - Pantiles (Astara):

This type of tile is found in the area stretching from Astara in the north down to Lisar, 50 km. to the south. There is also a tile kiln in Asalem, but tiles are less common than sheet metal, thatch and shingle roof coverings in this area. The production of "Astara tiles" is discussed in the section on Roofing Tile Industries.

"Astara tiles" are laid on horizontal battens. The dimension between two battens, top edge to top edge, is 23 cm. The small lip projection at the top end of the tile ("dokmeh") hooks over the batten. The bottom end of the tile overlaps the next tile down. Each tile overlaps its neighbour to the right (as viewed from in front of the roof). The ridges are covered by overturned tiles, held in place with cement. Cement is also used at the eaves to provide secure fixing to the bottom tiles, and on some buildings two horizontal rows of tiles midway up the slope of the roof are also cemented. There are 26 tiles per square metre of roof. These tile roofs are locally estimated to last 25 to 30 years. Due to the high rainfall and humidity and proximity to the sea, sheet metal roofs begin to leak within a few years and are consequently not as popular as the tile roofs.

A problem with both single lap tiles and double lap tiles (Behshahr) is the risk of moisture penetrating through to the roof structure below. This can happen when moisture is blown upwards by winds. Tiles should not be laid at too low a pitch, to prevent this from happening, and the overlap of tiles should be sufficient to avoid the upward penetration of moisture. Gaps and spaces between tiles allow air movement into the attic space, ventilating and drying timber structural members.

SINGLE LAP TILE
(Astara)

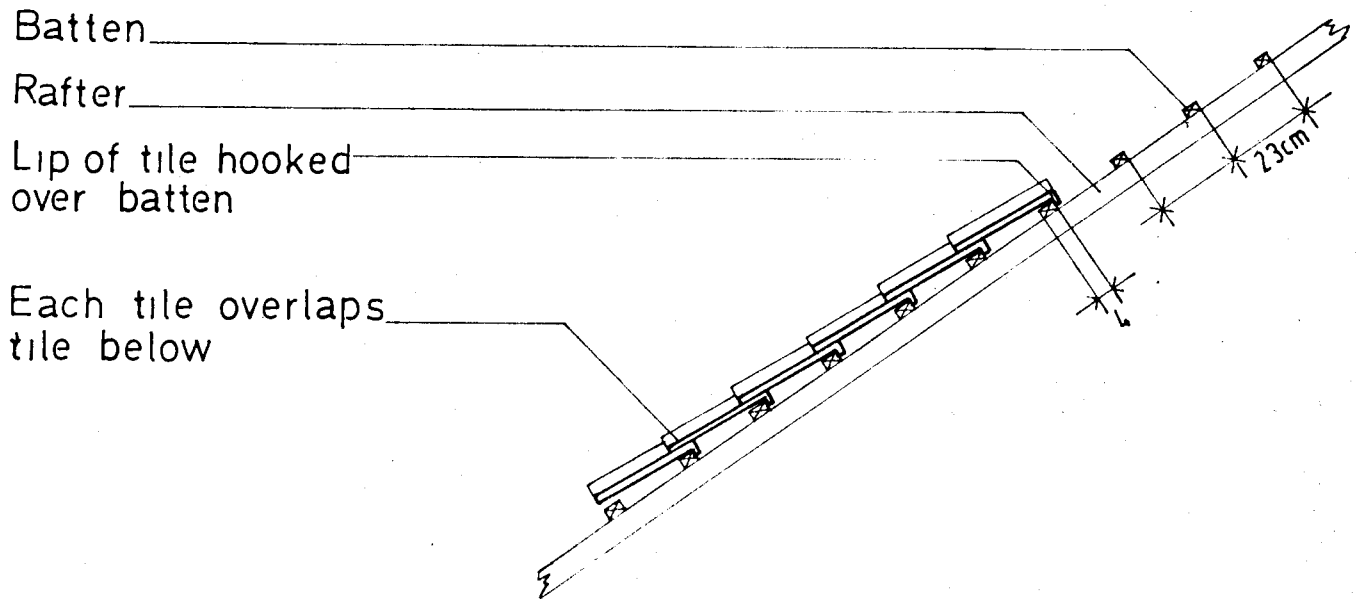
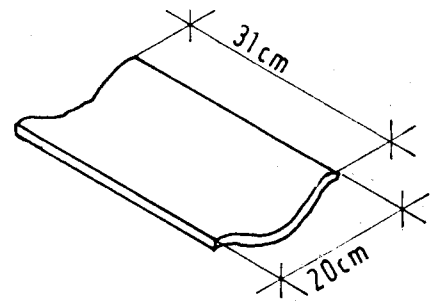

Seen from below
each tile overlaps
its neighbour to
the right

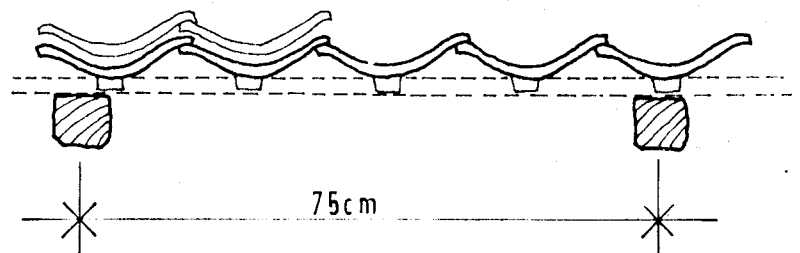

Tiles are nonflammable, and the only risk is that the supporting framework can catch fire. These tiles do not perform well in freezing conditions where moisture can penetrate small fissures in the surface of the tile, which expands on freezing and can produce cracks. This condition is not a problem in the Caspian coastal areas.

A roof covered with Astara tiles near Talesh. This roof has a clerestory, unusual in the area.



Detail of tiled roof in the Astara area.

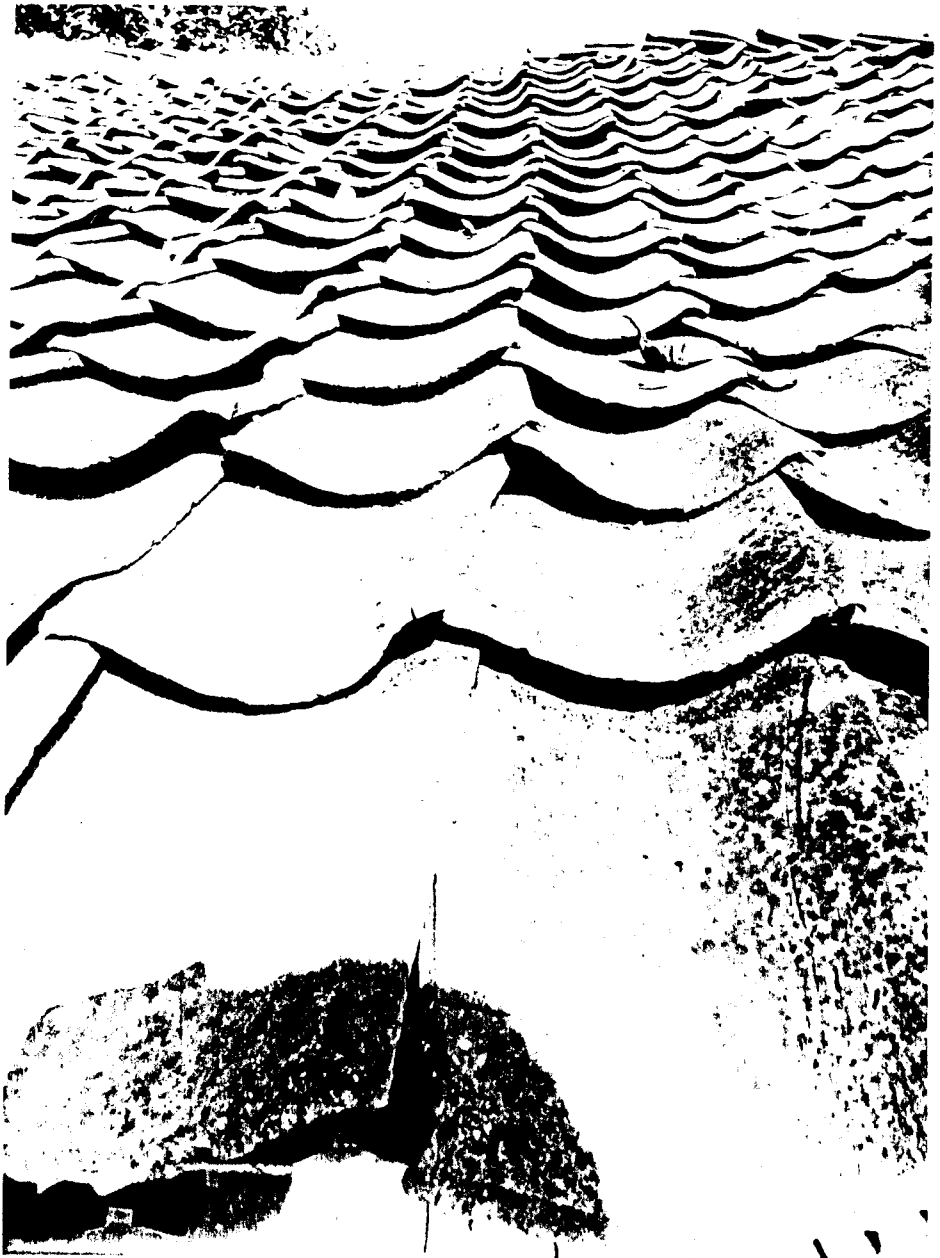

Double Lap Tiles (Behshahr):

Although tiles found in the Rasht/Lahijan area are slightly larger than those found in the Behshahr area, the method of laying on the roof is basically the same. Horizontal battens at 19 cm. centres are nailed to the roof framework. Tiles are laid on these battens, relying on their own weight and friction to keep them in place. The ridge and eaves tiles are cemented. The "under tiles" are laid with the narrow end down. The wider end is overlapped 5 to 6 cm. by the narrow end of the tile above. These tiles provide the channels for water run off, and project out approximately 10 cm. at the eaves to form spouts. The gap between two tiles lying side by side is covered by the "over tiles" laid with the wide end down, overlapped 5 to 6 cm. by the tile above.

It requires approximately 90 tiles to cover a 1m^2 roof area. Because of the small size of these tiles, the "under tiles" are almost completely covered by the overlapping "over tiles". A considerable amount of material is therefore used to cover the roof. If the individual tiles were larger the overlap of over and under tiles would be less and both material and labour would be reduced. Similar tiles used in Europe measure 35×18 cm. and are more efficient in use of material. In the Behshahr area tile roofs are more favoured than sheet metal. Tile roofs provide an even temperature in the roof space, which can be used for food storage. Sheet metal roofs transmit extremes of temperature to the interior, making them unusable for food storage.

However, sheet metal has become fashionable and a prestige material, and it has caused the production of tiles in this area to become almost negligible. Tiles used on new buildings are often second hand tiles from buildings that have changed to sheet metal roofing.

DOUBLE LAP TILE
(Behshahr) .

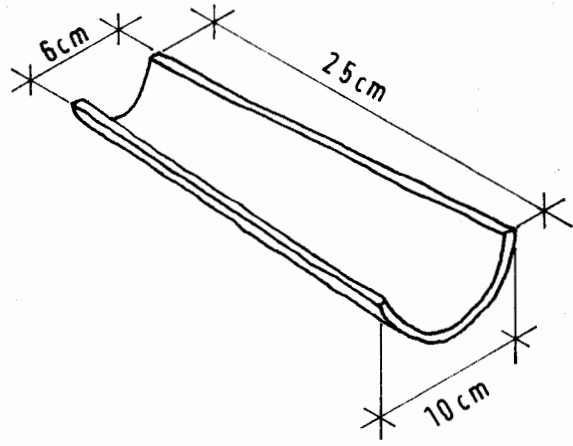

Battens

Rafter

Under tile

Over tile

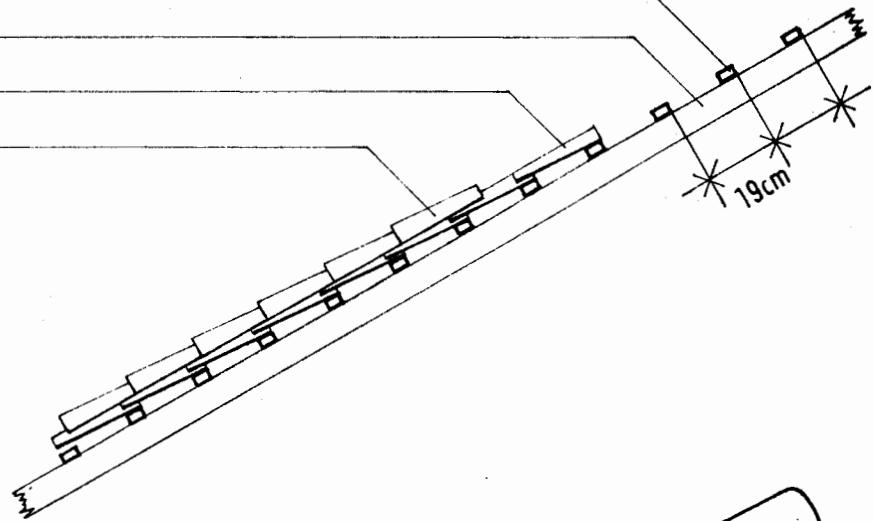

Over tile covers gap
between under tiles

Under tile

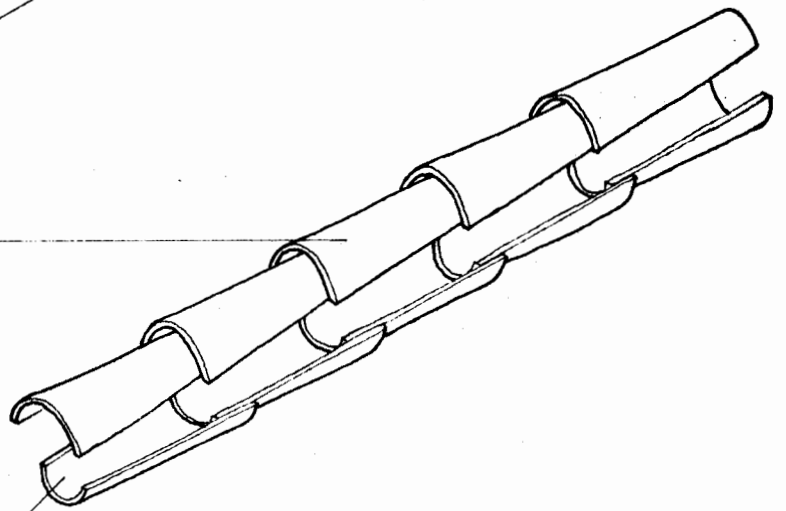

Because these tiles rely on friction between the tiles themselves and the supporting battens, they are potentially unstable in the event of the roof being shaken (eg., in an earthquake). The friction would be gradually increased if the tiles were laid on vertical battens, providing a continuous channel for the tile to rest in, with a greater area of contact between batten and tile. This would, however, only be economical if the tiles were larger. Tiles can also be nailed to the battens through a hole provided during the production of tiles. Distinction would have to be made between over and under tiles, since the position of the narrow and wide ends are reversed. The hole for over tiles would be unsuitable for under tiles unless placed within the section overlapped by the next tile below or above. Copper nails are the most suitable for use on tiles.

Flat Roofs Using Timber and Mud (Masouleh)

The flat roofs in Masouleh actually have a gentle slope (10°) which ensures that water will drain off efficiently.

The roof is supported by large beams (Shatir, jirien) at two metre intervals, which span across from side wall to side wall. These beams are tied together by a ring beam which runs round the perimeter of the wall. Laid over the main beams are a series of smaller beams at one metre centres (tir kouchek, varda). These too are attached to the ring beam at either end. In the past, pegged wooden joints were used to hold members together. These joints were extremely efficient. Nowadays, nails are often used for these joints.

The beams are covered with three centimetre thick boards (takhte), which form the base for roof covering. To separate the boards from the mud above, a two centimetre thick layer of bracken (Sarakhs, kharf) is used. In wet weather this bracken absorbs any moisture that may penetrate from above. In warm weather the bracken gives back this moisture to the earth above. In this way the boards below never come in contact with moisture. The bracken comes from the surrounding hills. Above the bracken mud is laid to a depth of about ten centimetres. Every four or five years an extra two or three centimetres is added to repair any damage that may have taken place since maintenance last took place.

The black earth that is used for the roof covering comes from the hillside opposite the town, and is apparently extremely water resistant. The local people say that this earth has lime and ash in it (Sarouj), and in that case the ash could account for the dark colour. Soil gradation tests have been carried out by the authors, and it was found that the soil can be classified as clay/sand, of which the highest propor-

MECHANICAL ANALYSIS

LOCATION: Masouleh, Gilan, Iran

SITE: hillside, roof soil

DATE: 24.10.78 Granulometric Chart

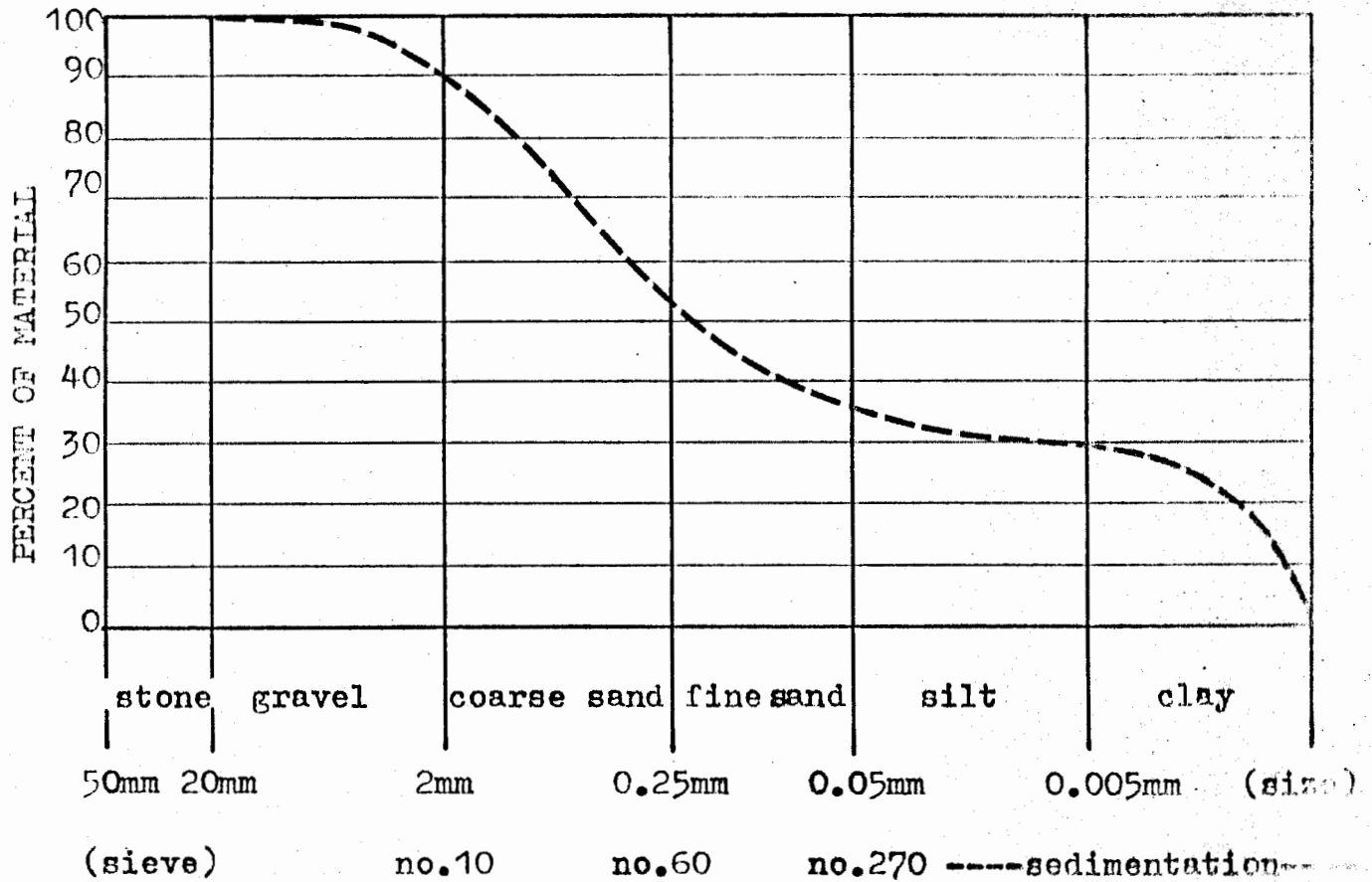

Particle Gradation

PARTICLE	mm SIZE	no. SIEVE	PER- CENT
Gravel	+2	10	25.95
Coarse Sand	+0.25	60	30.70
Fine Sand	+0.05	270	12.14
Silt	-0.05	270	5.37
Clay	.005	sed.	25.25

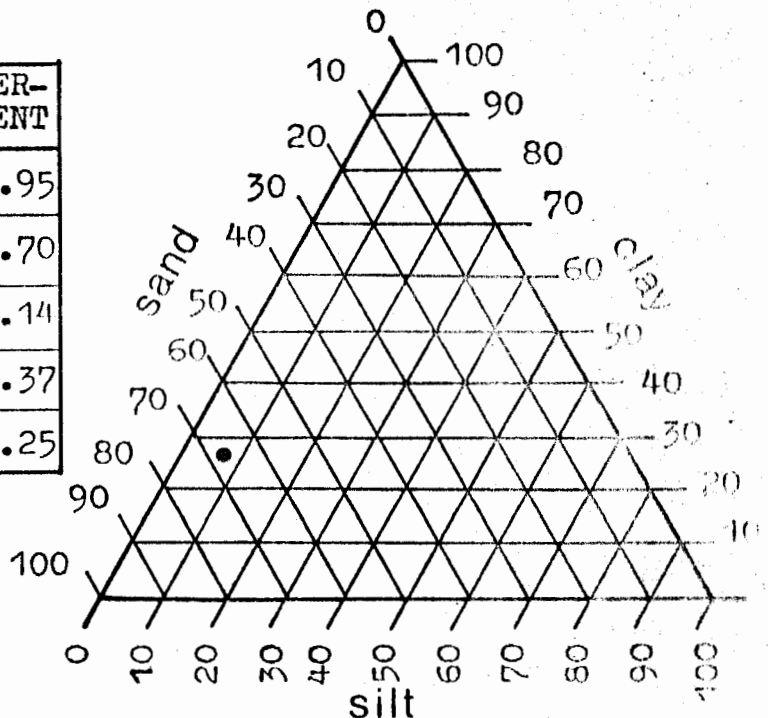

Soil Classification:

Clay-Sand

Classification Chart
(Gravel Eliminated)

tion of material is sand (coarse and fine) at about 43%. There is also a considerable amount of clay (about 25%). The accompanying chart shows the results of the tests.

the render is in good condition.

A more water resistant render is provided by a coating of lime whitewash, and it is frequently used at the base of a wall to a height of one metre, to prevent damage from water splashing against the wall. Such damage can undermine the wall and cause it to collapse. The lime whitewash is also quite cheap and lasts better than a plain mud-straw render.

In the mountain settlements of Kodir and Masouleh, the external walls of houses have an additional coating of mud on top of the render. In the case of Masouleh, this coating is applied quite thinly but can last for three years. This mud coating differs from that which is used on the flat roofs. While both came from sites on the hillside opposite the town, this mud can be classified as a sandy-clay, and is yellow in colour (see soil test chart).

MECHANICAL ANALYSIS

LOCATION: Masouleh, Gilan, Iran

SITE: hillside, render soil

DATE: 24.10.78 Granulometric Chart

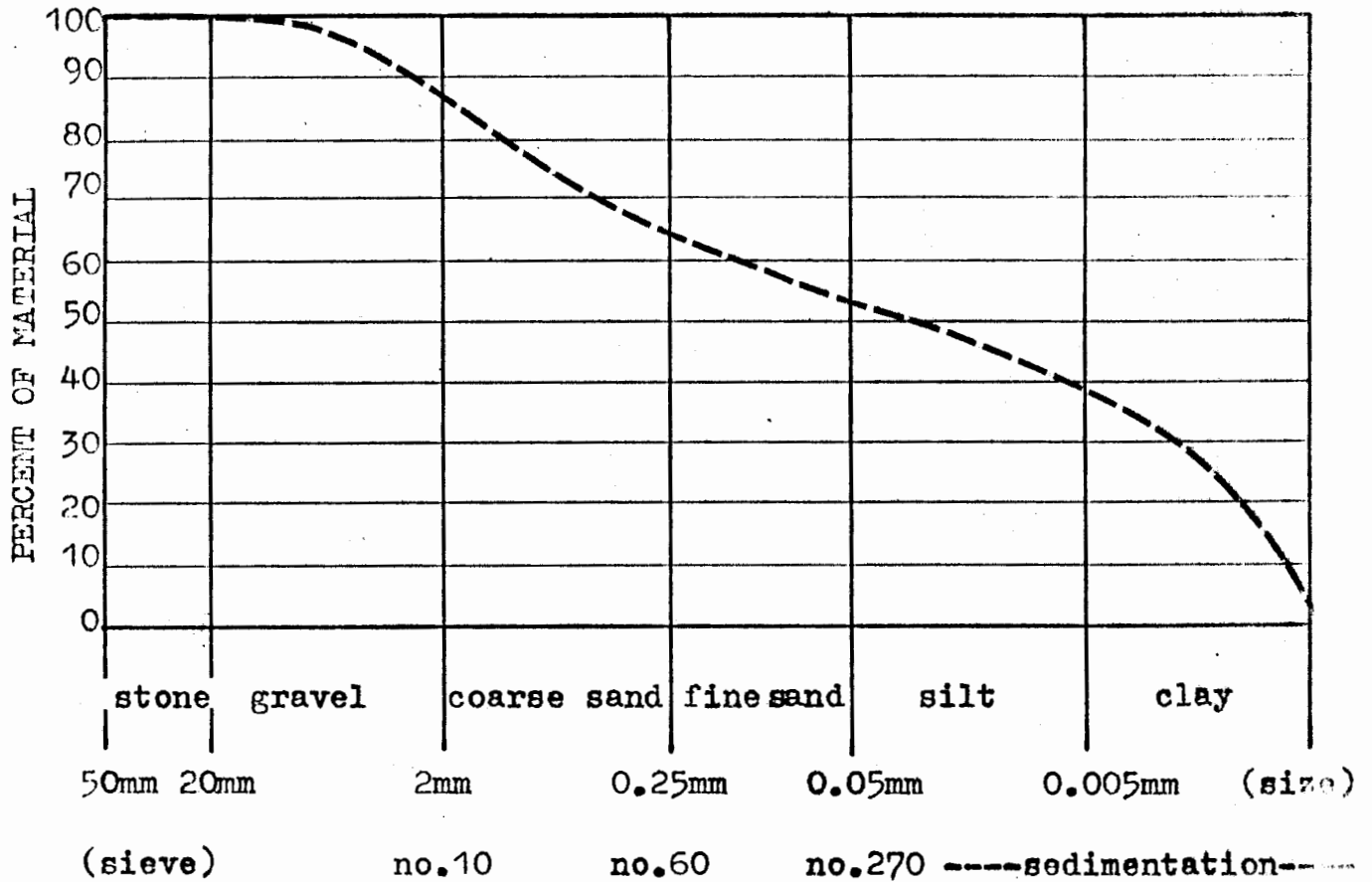

Particle Gradation

PARTICLE	mm SIZE	no. SIEVE	PER-CENT
Gravel	+2	10	24.49
Coarse Sand	+.25	60	16.00
Fine Sand	+.05	270	11.79
Silt	-.05	270	17.52
Clay	.005	sed.	29.57

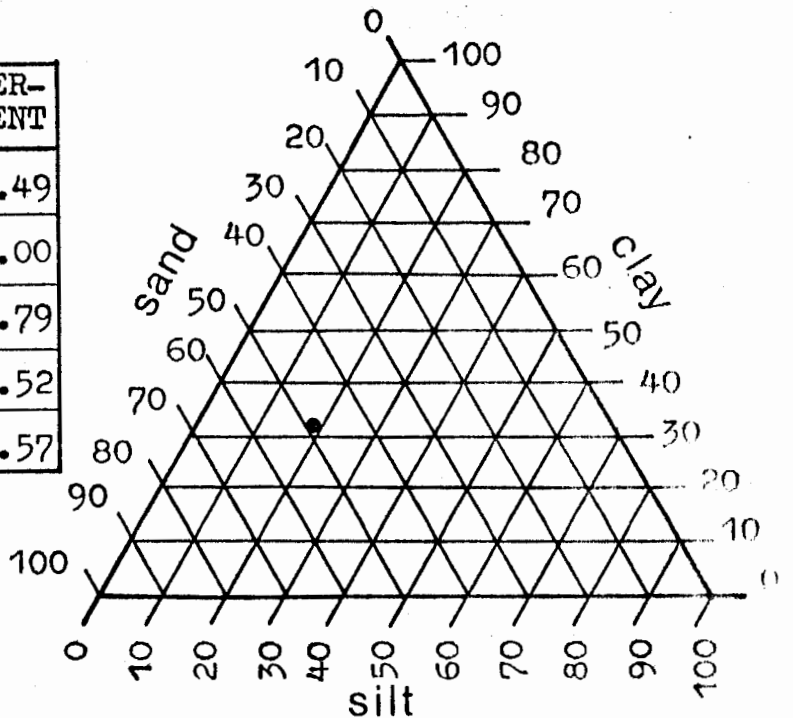

Soil Classification:

Sandy-Clay

Classification Chart
(Gravel Eliminated)

Masouleh
Soil Profiles

Wall Render Sample

- bracken
- grey - brown
- yellow - brown clay
- white chalk streaks
- yellow - brown clay
- gravel

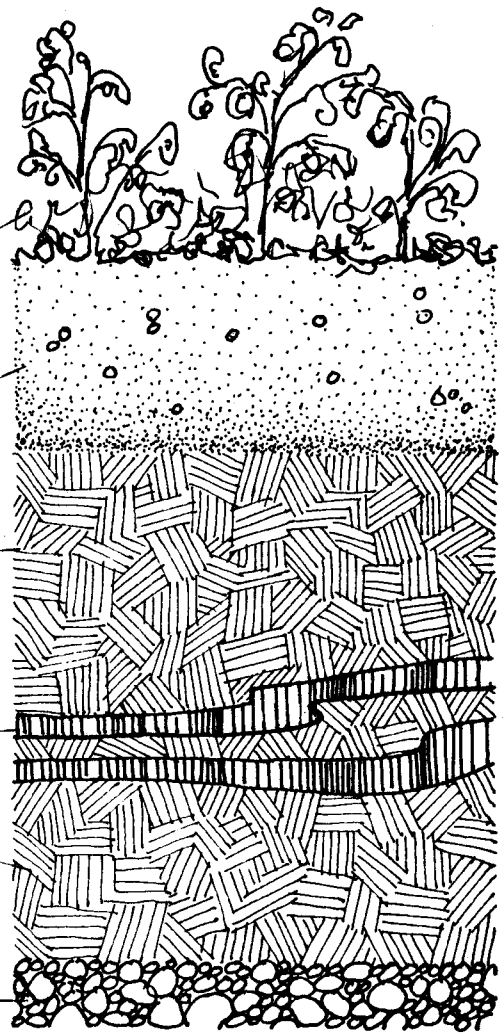

Roofing Material Sample

- sparse grass
- grey - brown gravelly
- black - clay gravelly
- yellow - brown clay gravelly
- gravel
- stone

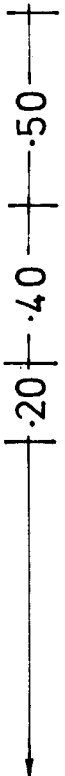
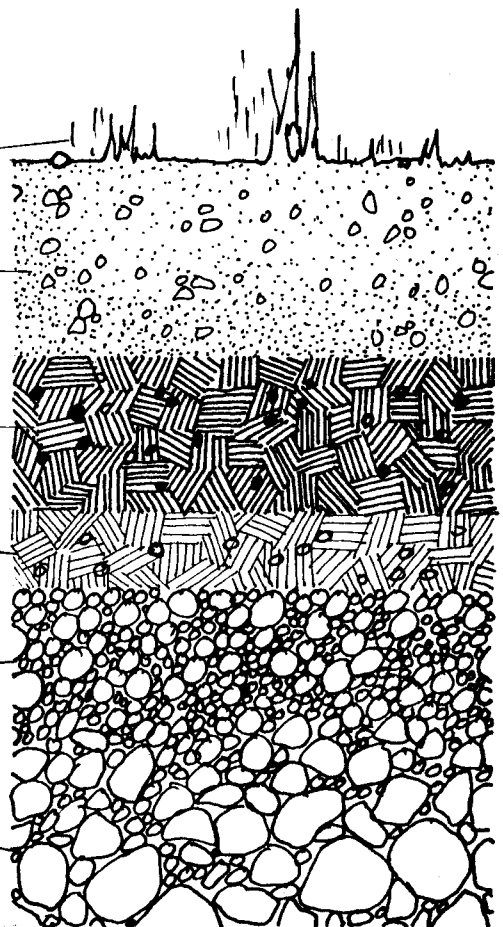



Unrendered log walls are untidy and the mud packing can be washed away.

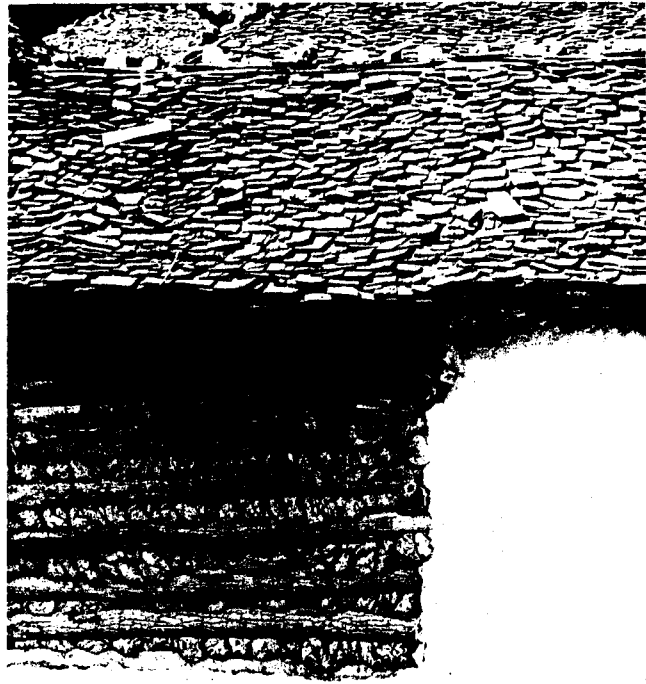

Section of log wall before rendering after repairs.



The interlocking corner detail on rendered log wall.



Women repairing the wall render on a Kodir house.

Roof Truss Frameworks:

Roof trusses can be divided into three main indigenous types within the Caspian Region. Subtle variations do occur, which are often the result of the differing skills of local builders and the requirements of different roof coverings.

The roof trusses have been divided here into the following:

- A. Shallow pitch (25° - 35°)
- B. Medium pitch (40° - 50°)
- C. Steep pitch (55°)

A. The shallow truss type (25° - 35°) is used with roof coverings of shingle, tile and sheet metal, although in each case the arrangement of the battens is different.

The roof truss has a vertical central post and hangers on either side, but no struts. The ceiling joists span between the walls and to the framing on the aivan. They rest on a wall plate fixed to the top of the wall. The overhang of the joists varies depending on the covering material and the area; it's between 50 cm. and 1 m. At the eaves is a plate, forming a ring beam round the building, to which the rafters are attached. At the centre of the truss section, and midway along each half, are runners resting on the ceiling joists. These in turn support the central posts and the hangers on either side. The latter are steadied by diagonal braces where necessary. At the top of the central posts the ridge pole is fixed. Purlins are similarly fixed to the top of the hangers. Rafters at approximately 40 cm. centres span from the ridge to the eaves. The fixing of the rafters to the purlins and ridge pole is done with string on simpler buildings; but nails are used where the standard of joinery is better and squared timbers have been used. Battens are either tied or nailed to the rafters. In the case of tile and shingle roofs, the battens are usually small in section (see tile and shingle roofing section), but where sheet metal is used as a covering,

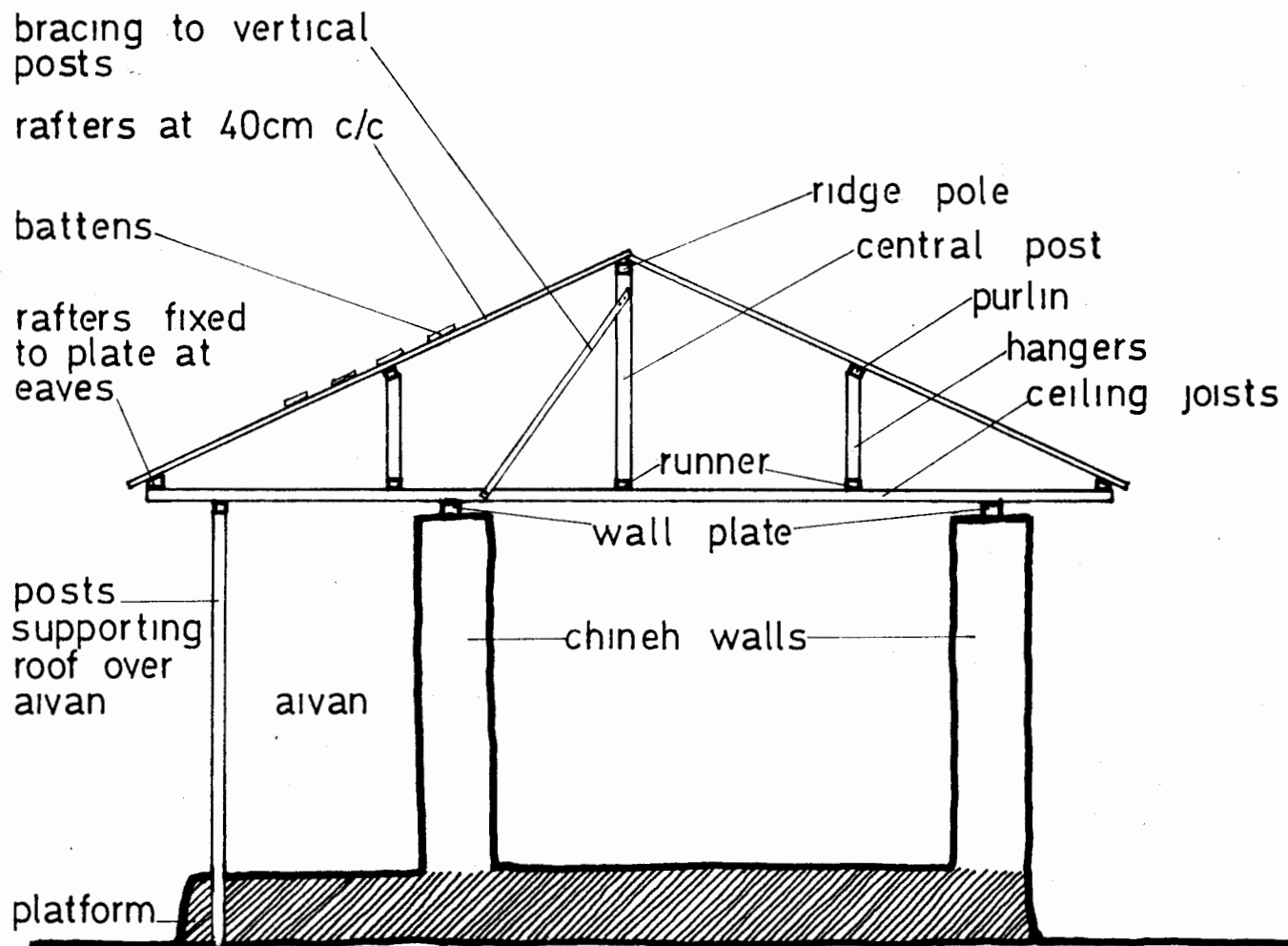

A ROOF TRUSS with vertical posts, used on low pitch roofs (25° - 35°), with shingle, tile or sheet metal covering. Surveyed in Sar Marz, Mazandaran.

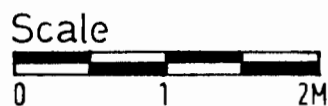

boards are nailed over the rafters to provide a flat surface for the sheet metal to lie on, and a fascia board is nailed to the rafters where they overhang at the eaves. This is covered by metal sheeting, usually with cut out decoration.

B. This is a roof truss with a single tier of struts used on medium pitch roofs (40° - 50°). The covering is thatch, mostly of rice stems but sometimes with reed. Ceiling joists span between walls and the framing at the edge of the aivan. On the aivan side these ceiling joists project out 50 cm. beyond the front of the building. At the outer ends of these joists a rail is fixed, forming a ring beam around the building. The central post (as noted in the house of a local builder interviewed) is fixed into the top of the wall dividing the aivan from the rooms. It would be better if this post rested on a beam at the top of the wall, spreading the point load. These posts are at 2 m. centres and continue up to the ridge, where a ridge pole rests on a natural or artificial 'Y' bracket. Thin diagonal wooden braces are used to steady these vertical members where necessary. Round section timber rafters run from the ridge pole down to the eaves. In the Fouman area the rafters at the rear and one side (north and west sides) project down and beyond the walls, to stop about one metre out from the main building. At this point a wall, usually of mud, connects the eaves to the ground. Rafters are spaced at 35-40 cm. centres. Purlins are attached with a string woven from rice stems, to the underside of the rafters at $1/3$ and $2/3$ intervals up the side of the roof. After the rafters are in position, struts are put in between the lower purlins and the runners (the runners rest on the ceiling joists) and between the upper purlin and the central wall (see section). These struts provide stiffening to the roof framework as well as resistance to any sag that may occur in the rafters. The battens are attached to the rafters with string. Their spacing depends upon the method of thatching being used (see section on thatching). This truss uses a minimum of sawn timber.

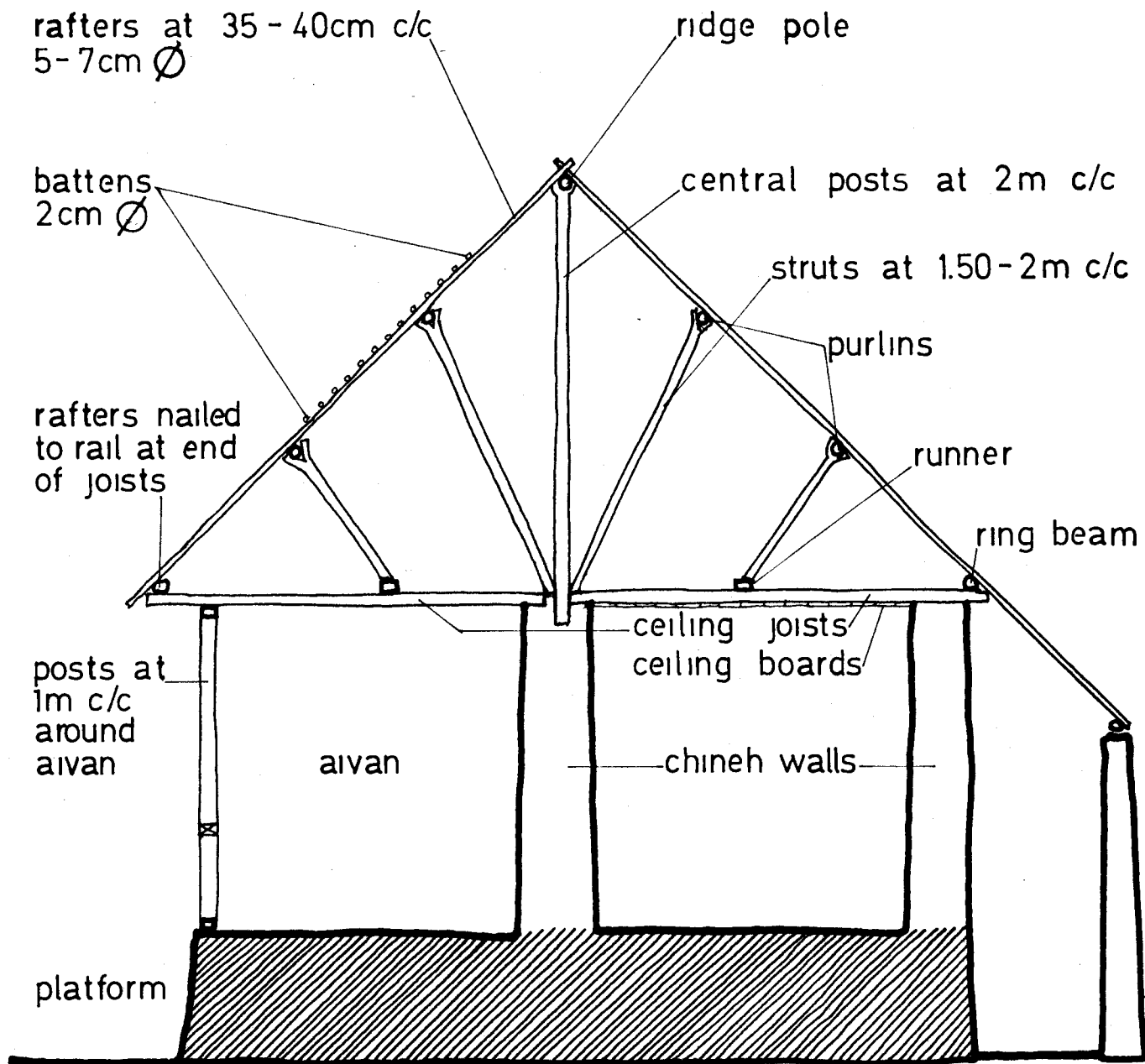

B ROOF TRUSS with single tier of struts, used on medium pitch roofs (40° - 50°), with thatch covering. Surveyed in Dogoor, Gilan.

Scale

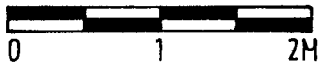

Because of the regular use of struts, the size of the rafters can be quite thin. Compared to a flat roof of similar span, the pitched roof makes economical use of thin poles which are cheaper and easier to obtain.

C. A roof truss, unusual for having two tiers of struts, is used on steep pitched roofs (55°). The covering is thatch, either of rice stems or reeds. In constructing this type of roof the framing of the walls is first capped by a ring beam, over which horizontal squared beams are laid at approximately one metre centres. These beams carry the smaller ceiling joists and plates at the eaves. Another set of squared beams are laid over the ceiling joists. This strong platform supports the runners to which struts, hangers and the central posts are attached (see drawing). For the remaining truss members round members are used. Hangers at 1.50 m. centres connect from the runners to purlins half way up the side of the roof. Thin wooden braces are used to steady these vertical members where necessary. Purlins on each side of the roof at this level are connected by a collar supported centrally by a central post. Over the centre of the collar is another runner, in turn carrying the upper half of the central posts. At the ridge is a horizontal pole (the ridge pole) on which rest the rafters, at 40 cm. centres, coming up from the eaves on either side. When the rafters have been put in place, additional purlins are added under the rafters at $1/4$ and $3/4$ distances up the side of the roof. Between these purlins and the runners below, diagonal struts are placed, spaced at 1.50 m. centres. The bracing effect of these struts provides stiffness and rigidity to the rafters and framework in general. Additional secondary struts are placed at 3 m. centres between the purlins half way up the side of the roof and the runner below the central post. Purlins, rafters and battens are all attached with string. Nails are used at the foot of the struts and hangers. Battens are laid horizontally on the rafters. Their spacing varies depending on the type and method of

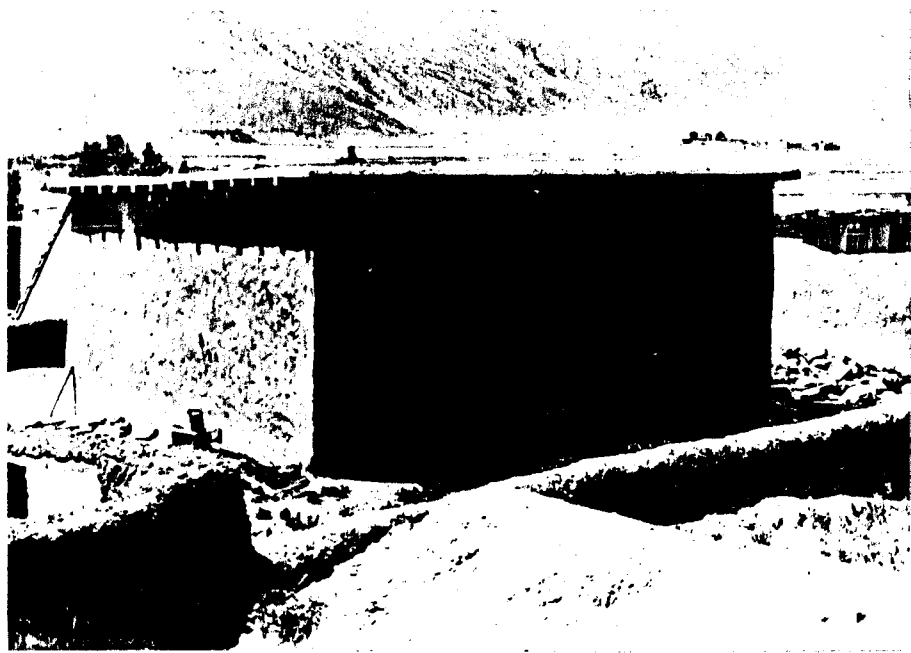

Flat roof house in Kojur.



Walls are made of stone and mud.
The roof is built as a single framed unit.