

Report: Upgrading Roof Tile Industry
Caspian Region - Iran - 1978-79

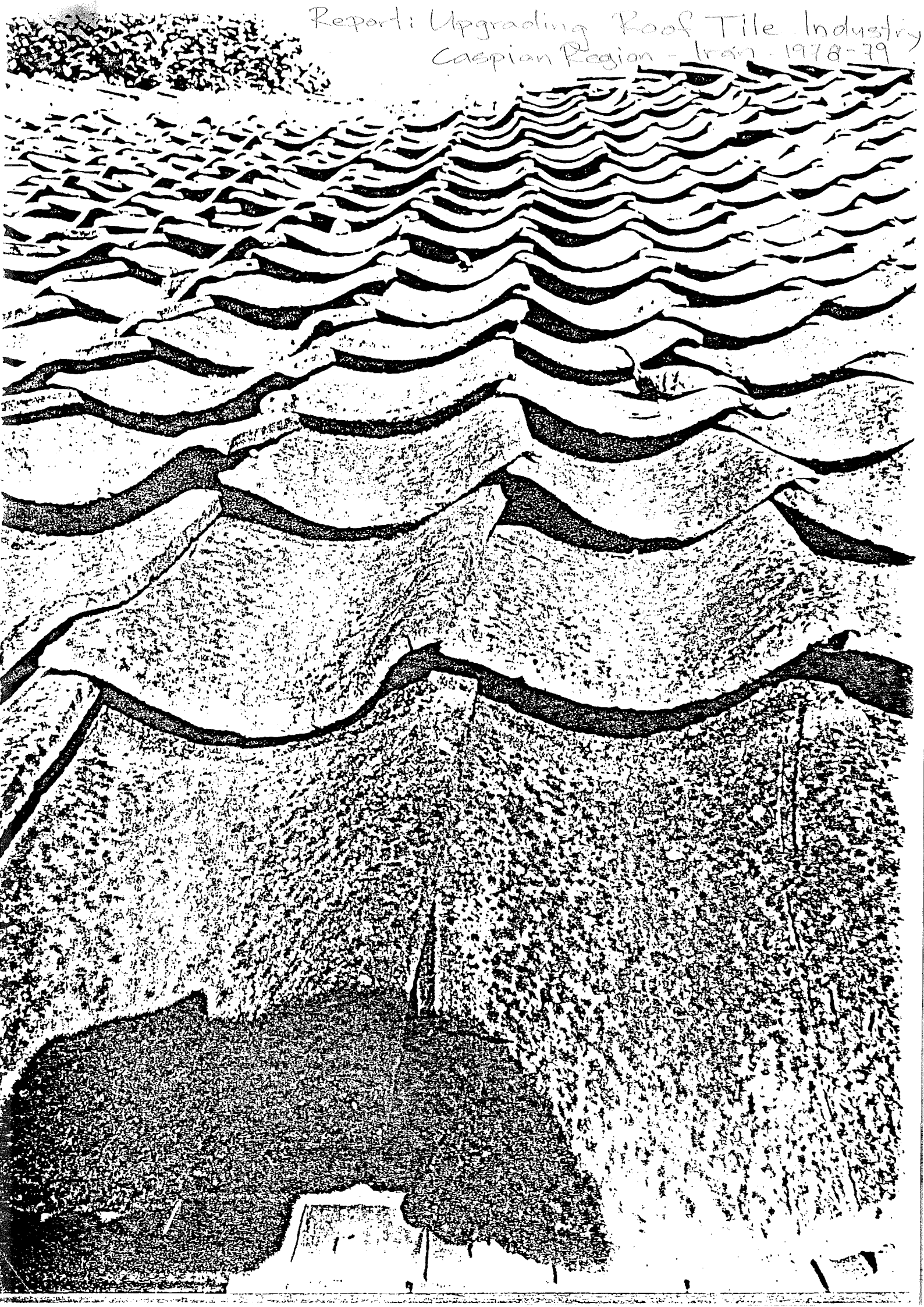

Roofing Tile Industry

Roofing tile production in the Caspian region is an example of a decentralized rural industry which utilizes local resources and labour to meet local housing needs. Until recently, tile was produced in many areas throughout the Caspian, but today most producing kilns are found on the western Caspian coast.

Roofing tile has been produced in the Caspian region at least since early Islamic times. South of Bandar Gaz in Mazandaran remains of the city of Tamis or Tamisha have been excavated, including an early Islamic citadel with roof tiles similar to those used in the Caspian today. The city was apparently destroyed in 1220 A.D.*¹ There are early references to tile roofs built by Seyyed Razi Kia in the Langarud district in the 1400's*² Later, in 1627 Herbert talks about tiled houses in Farahabad, north of Sari*³ and in 1717 J. Bell makes reference to tiled roofs in Rasht*⁴. Again, Fraser in 1822 notes Astarabad (Gorgan) having "pitched roofs with red tile...extending far beyond the walls; many with four sided badgirs (windcatchers) with tiled roofs". He also mentioned that the bazaar was tiled at that time.

It can therefore be assumed that there has been an ongoing tradition of the use of tile in housing and public building for many centuries in the Caspian region, although its earliest use can not be established definitely.

1* Roger Stevens, The Land of the Great Sopleh, 1971, p.132.

2* H.L. Rabino, Les Provinces Caspiennes de la Perse, 1917, p.250.

3* W. Foster, Thomas Herbert Travels in Persia 1627-1628, p.174.

4* John Bell, Voyages de Saint-Petersburg a Divers Parties de l'Asie, 1763, vol.1 p.133-5.

Regional Differences:

Tile production in the Caspian can be broken down into several regions as to the nature and form of the tile produced, its production method as well as its current viability as an industry. Beginning geographically in the west, the region stretching between Astara and Lisar has a viable local tile industry today producing a large "pan" type tile measuring approximately 31 cm.x 20 cm. and about 1.4 cm. thick. The use of this type of tile is extensive today in new building, particularly in rural but also urban situations. The introduction of this "pan" tile is difficult to establish historically, but local people tell of its use over at least the last several generations. Tile is the predominant roofing material in this region and is preferred for economic, maintenance and environmental reasons over other indigenous and newly introduced roofing materials.

The second area, or central Caspian region, includes the Rasht plain, the Lahijan/Langarud district and extends along the coastal strip into Mazandaran. This area, once noted for its red tile roofing, no longer supports an active tile industry. The soils in this area are generally considered poor for ceramic industries and even most brick kilns have fallen into disuse. Tile roofs in the region are to be found on older urban structures, and particularly in the bazaars. Very few new buildings are roofed with tile in this region, and of those that are most have used second hand tile or imported it from outside the area. The old tile of the Rasht-Lahijan area is semi-cylindrical, tapering to one end and measuring about 11 cm. at the wide end, tapering to about 7.5 cm., and is about 26 cm. long and 1 cm. thick. Tile has apparently not been produced in this area for a number of years and local skills have probably been lost.

The third principal tile area considered in this study is the Sari plain. Tile production has in the past been centred in

the area between Neka and Behshar. A tile industry operated here until very recently, although during the period of study no kilns were noted to be functioning. Tile kilns were surveyed and tile kiln operators were interviewed. There has been little or no tile production in this area for the last two or three years.

The tile produced in this area resembles the Rasht tile in colour and shape, but is somewhat smaller in size and weight. It measures about 10.5 cm. at the wide end and tapers to 6.5 cm. and is 24 cm. long its thickness varies from approximately .7 cm. to 1. cm.

Although production of tile has apparently stopped, the use of tile for rural and village housing is continuing. The demand for tile is met by recycling used tiles and utilizing stocks which still remain from several years ago. Tile is still the preferred roofing material for many house builders in the area for environmental and economic reasons. The alternative new material, galvanized metal sheeting, proves to be more expensive by a factor of more than 10%.

It is felt by the authors that a revitalized tile production in this area could contribute to the housing industry and provide local employment. An analysis of the reasons for the local decline will be made in the following pages. The transfer of some aspects of the tile technology of the Astara-Hashtpar region may act as a stimulus.

Astara-Lisar Tile Industry:

The present decentralized nature of tile production along the western Caspian coast can be illustrated by the fact that there are approximately fifty tile kilns operating between Astara and Lisar. These are largely rural industries operating in the vicinity of village settlements on the coastal plain immediately adjacent to the foothills. Each small village may have a number of kilns employing local labour from that village. Tile production units in this area do not normally have onsite sources of ceramic clay. Clay is quarried from select sites in the foothills, which may be up to several kilometres from the kiln and production yard.

A sample of tile clay was collected in the Chubar area, about 25 km. south of Astara. Detailed tests were carried out by the authors on this sample to establish its composition as to particle gradation. It was discovered that the sample had a very high proportion of fine particles and little sand and no gravel. The principal constituent at about 60% was silt. Such a soil can be considered suitable for making ceramic products such as tile.

The general location of the kiln is determined by its proximity to not only the raw clay source, but also the accessibility of timber for fuel, transportation links to neighbouring markets, labour, and quantities of available fresh water for mixing. To these one might add the consideration of smoke pollution from kiln exhaust and hence the kilns' relationship to existing settlements. Kilns should ideally be located after determining prevailing and local wind patterns, downwind or to the lee of villages and towns.

A number of tile production units visited in the region and a detailed study was carried out of a kiln near Chubar. The

MECHANICAL ANALYSIS

LOCATION: Rustam Kolah, Mazandaran, Iran

SITE: tile-kiln

DATE:

Granulometric Chart

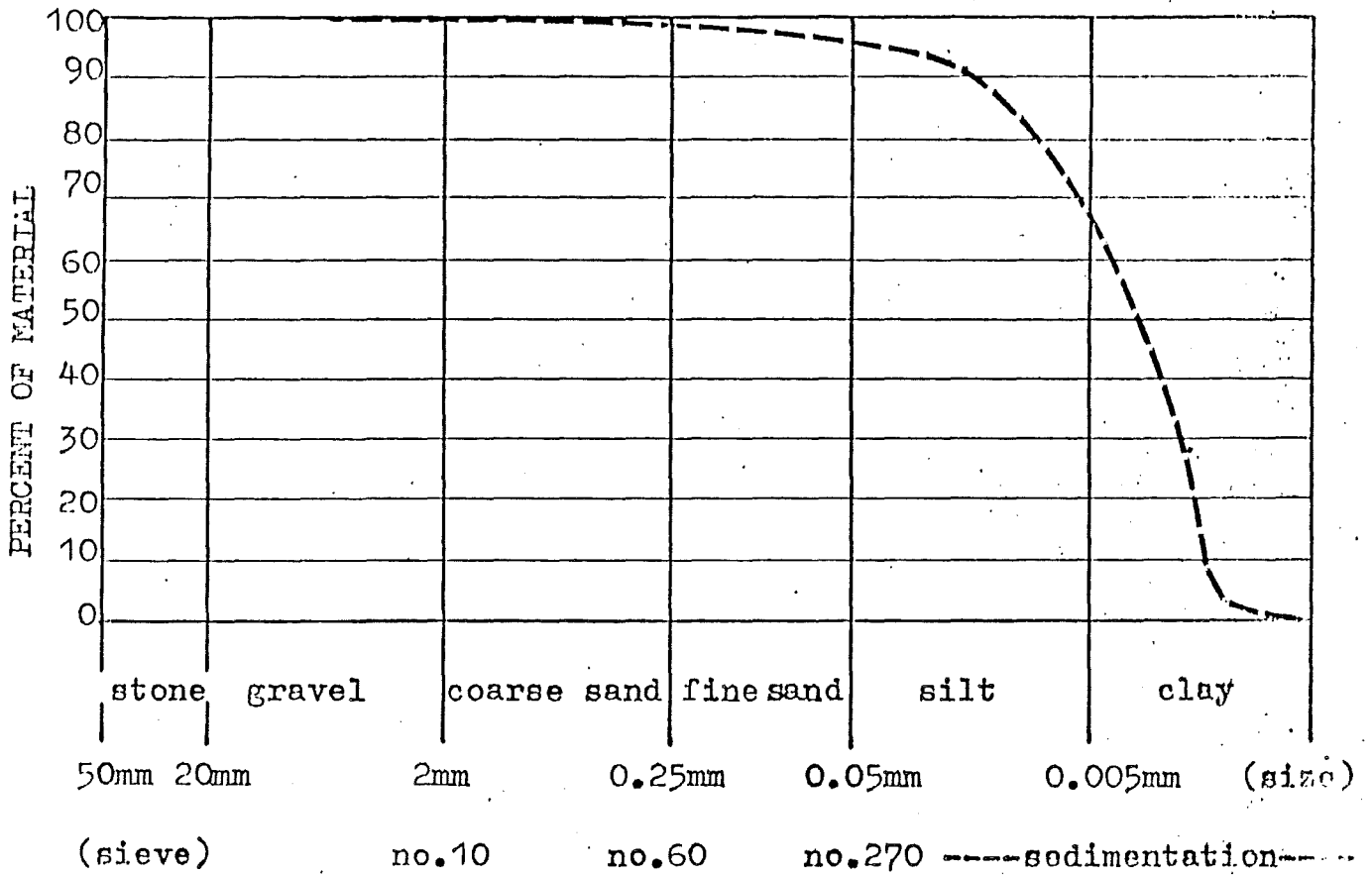

Particle Gradation

PARTICLE	mm SIZE	no. SIEVE	PER-CENT
Gravel	+2	10	0.00
Coarse Sand	+.25	60	1.54
Fine Sand	+.05	270	6.68
Silt	-.05	270	80.42
Clay	.005	sed.	9.80

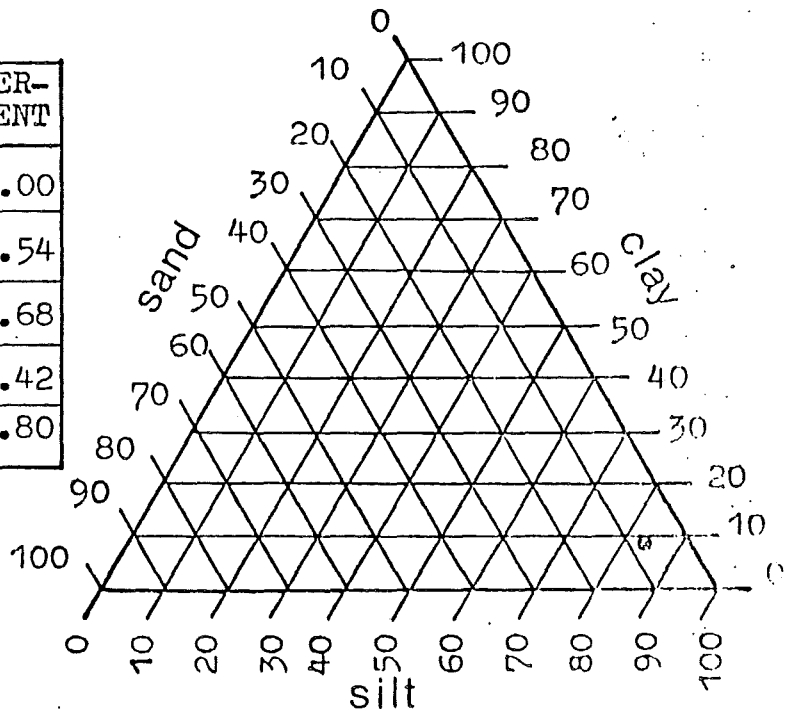

Soil Classification:

silt

Classification Chart

The Chubar unit can be considered fairly typical to the region and has an output of two hundred to three hundred thousand tiles per year. The production season is limited by climate to six months in spring and summer. In other seasons heavy rainfall and cold interfere with tile making and kiln firing, and very high humidities will not allow proper drying.

Tile Production Unit
Chubhar , Gilan

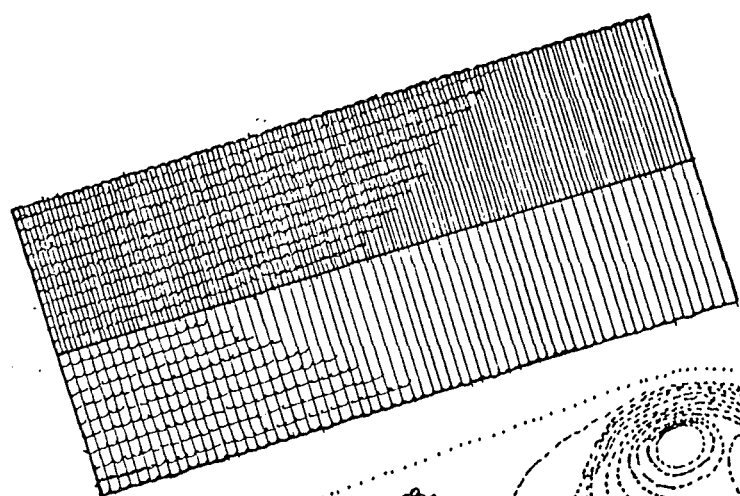
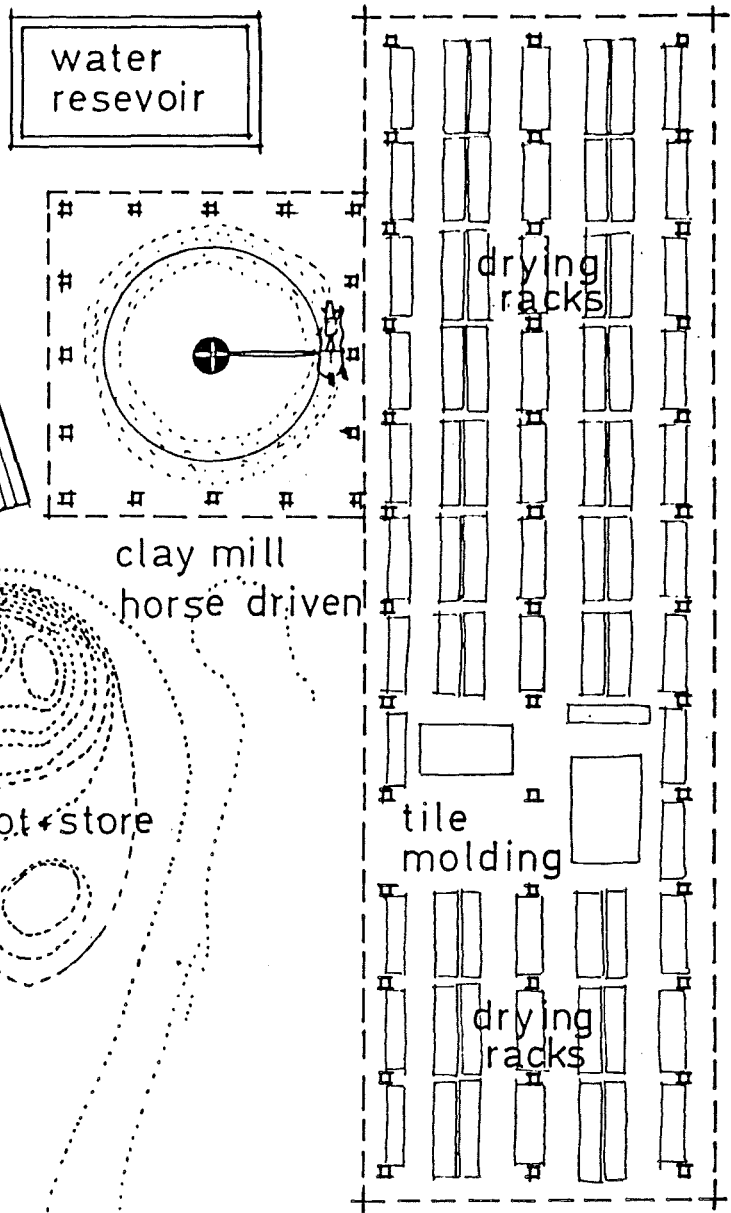

drying shed



clay depot + store

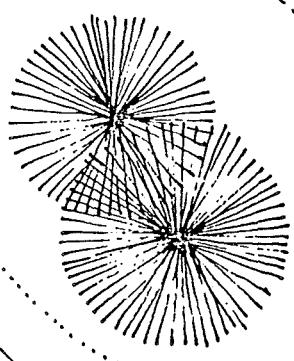

clay mill
horse driven

to main road

kiln



fuel

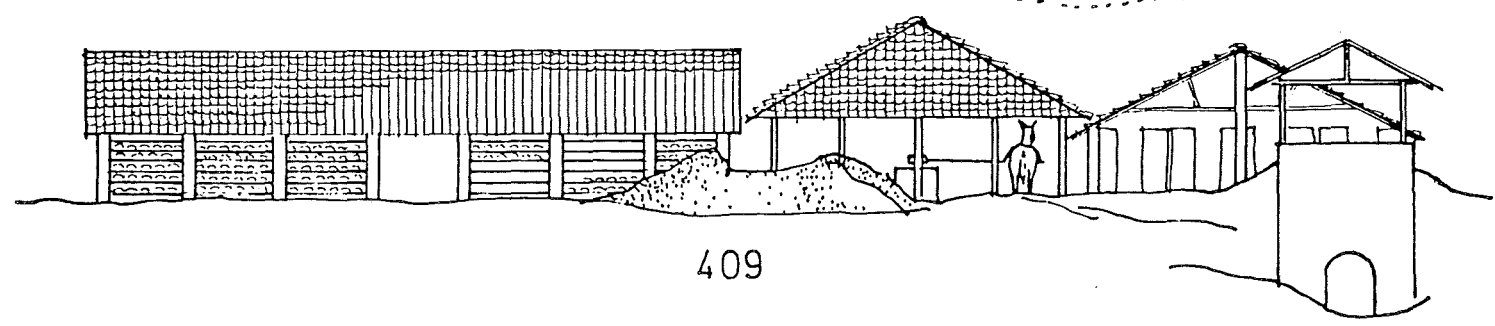
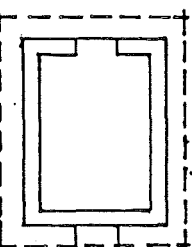

Tile Production: Case Study A

Tile making is essentially a labour intensive process. The kiln studied employed a total of five people. One man ran the horsedrawn clay mill. He was responsible for the processing of the clay after its delivery to the site. Clay is first mixed with water and allowed to stand for a period of several days. The clay becomes saturated and lumps are broken down. The clay, now in a plastic state, is moved to the clay mill. The mill is a simple apparatus made from a discarded 200 litre oil drum. A shaft with mixing arms is fixed so that it can be rotated by a wooden beam tied perpendicular to the axis. The mill is driven by a horse which follows a circular track around the central turning axis. Clay is shovelled into the mill and the mixing arms knead the clay to a uniform mass. The clay now having a stiff consistency, is retrieved from an outlet at the base of the drum of the mill. Clay is delivered to the working/drying sheds for moulding.

Drying sheds are long pitched roof structures without walls, open to air movement, which is important to the tile drying process. Tiles must be dried under roofed shelters for rain protection and for protection from direct sunlight which may cause cracking due to too rapid drying. In the centre of these sheds a space is set aside for the work of moulding. An assistant takes the clay which has been brought from the mill and forms it into lumps, each enough for one tile, then rolls it flat. The tilemaker, working at a bench, first cleans his shallow concave mould and sprinkles a handful of sand over it to prevent sticking. The clay is pressed into the mould with a cylindrical wooden roller. When a proper uniform thickness has been achieved, and the clay has been pressed into the indentation forming the tile's lip projection, excess clay is trimmed off with a stretched wire cutting im-

Clay Mill
for tile production
Chubhar, Gilan

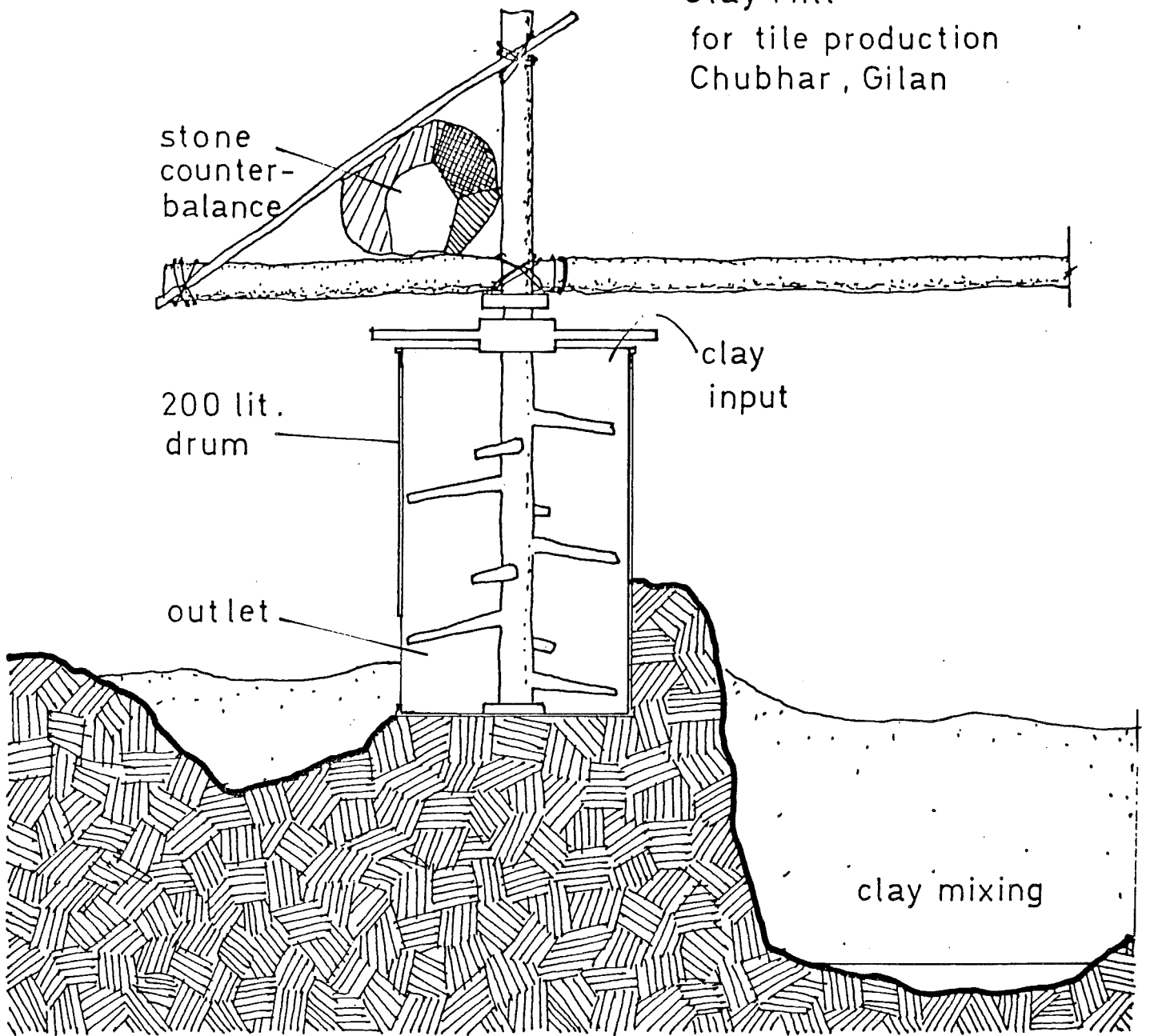

Section

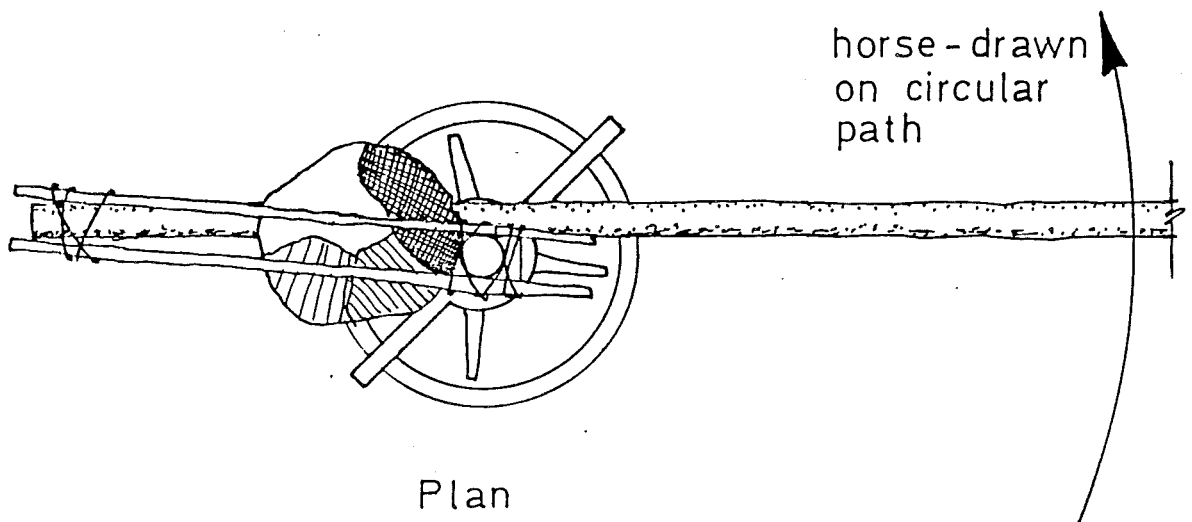

Plan

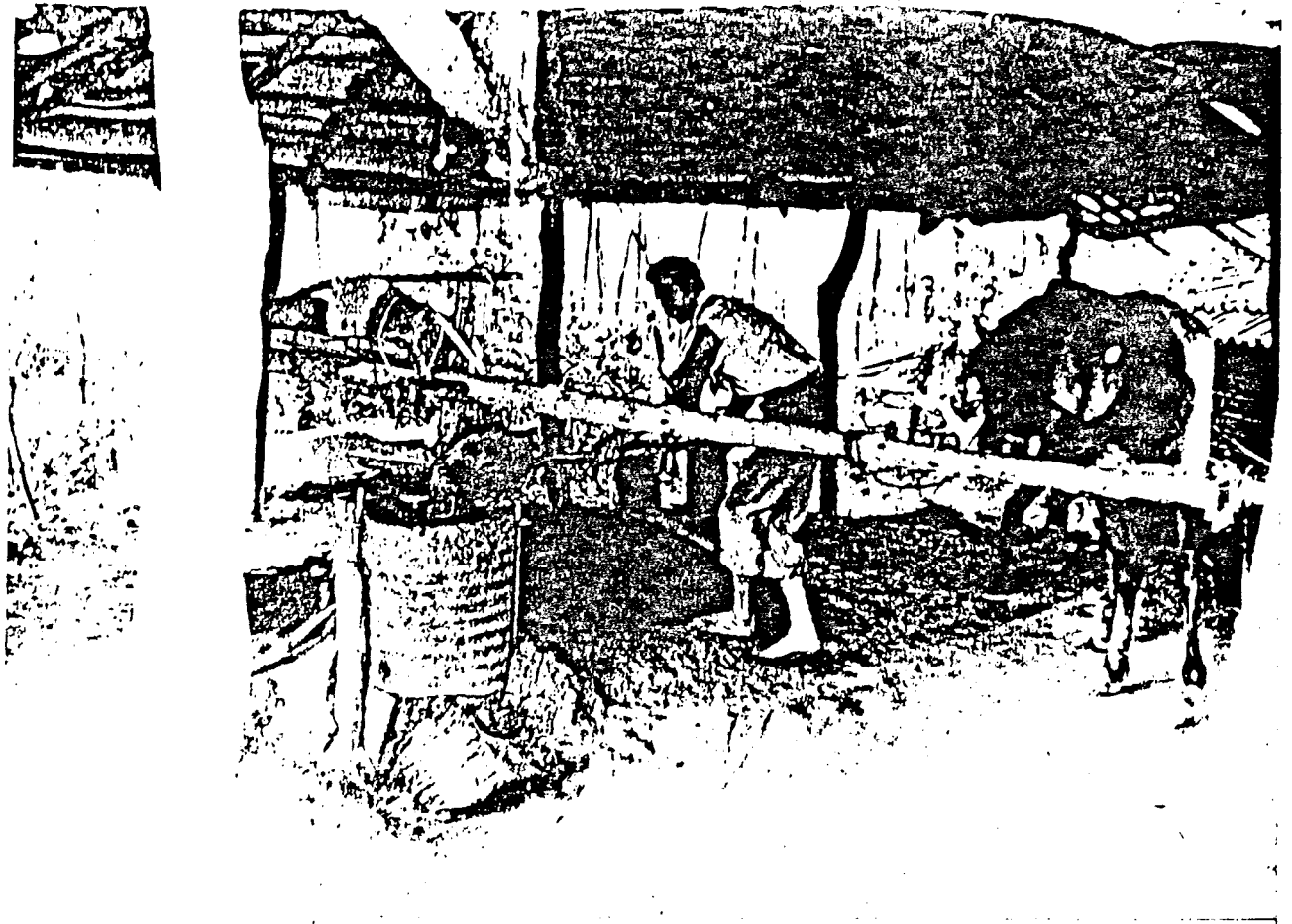

Horse drawn clay mill in Chubar.

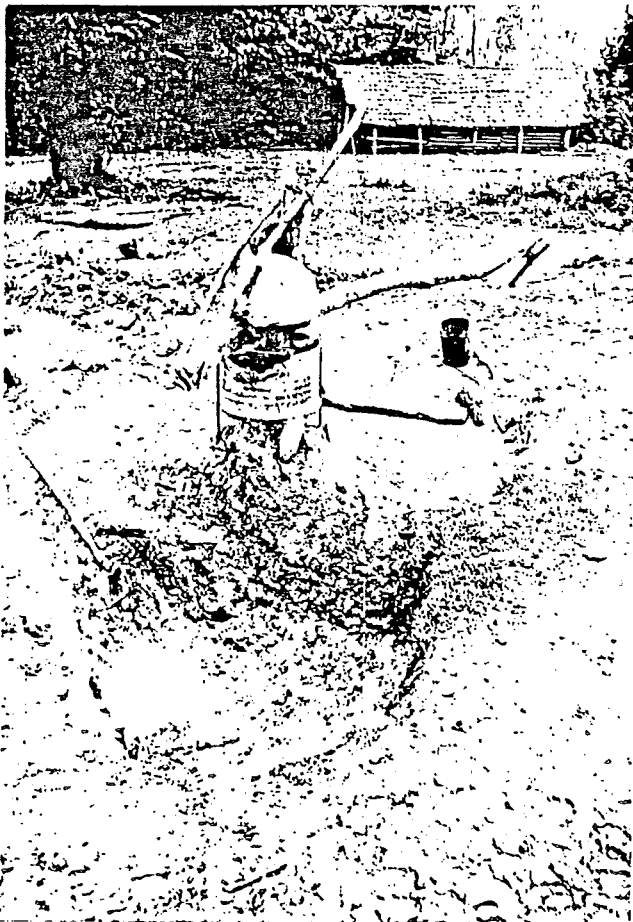

Details of clay mill.

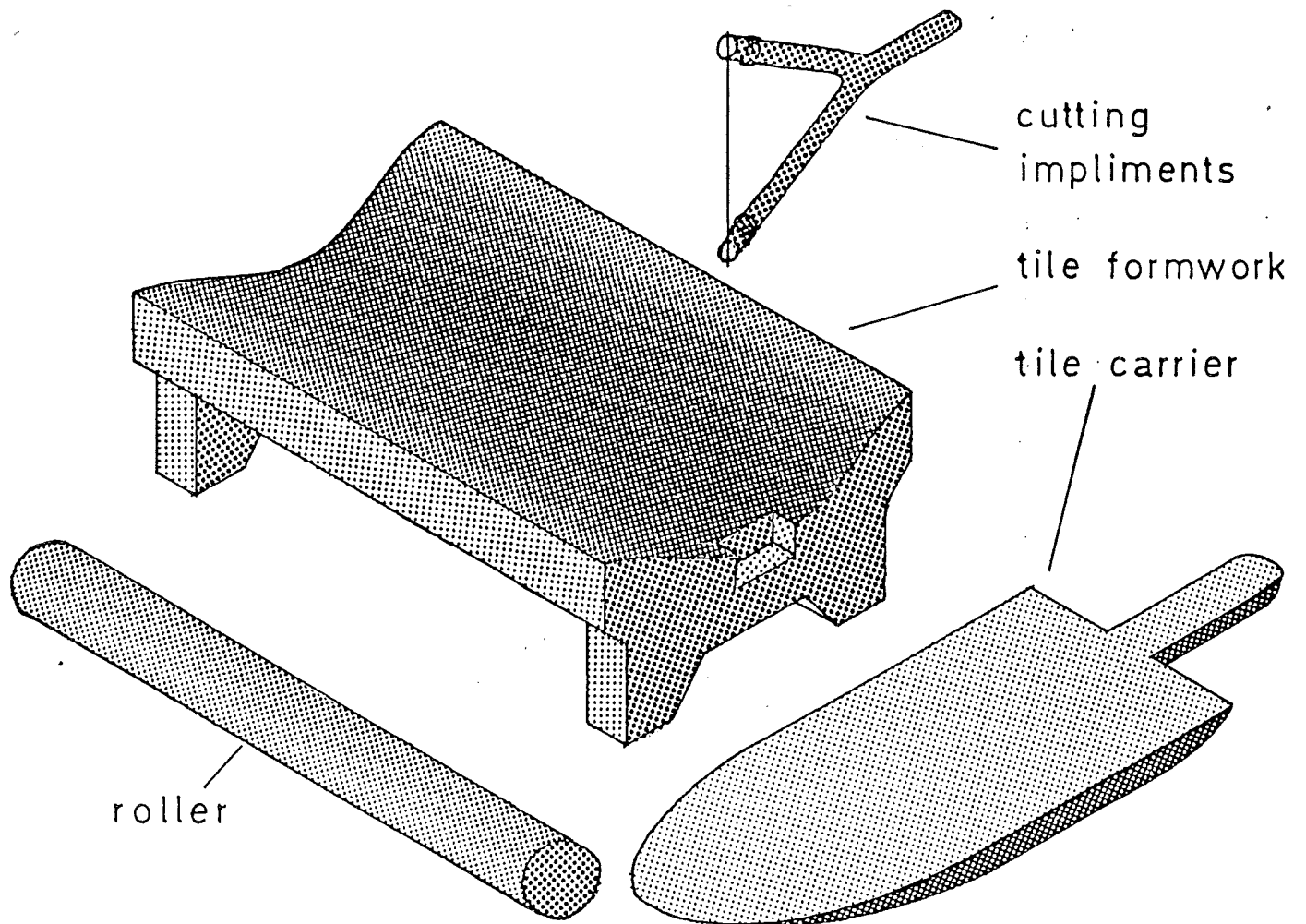
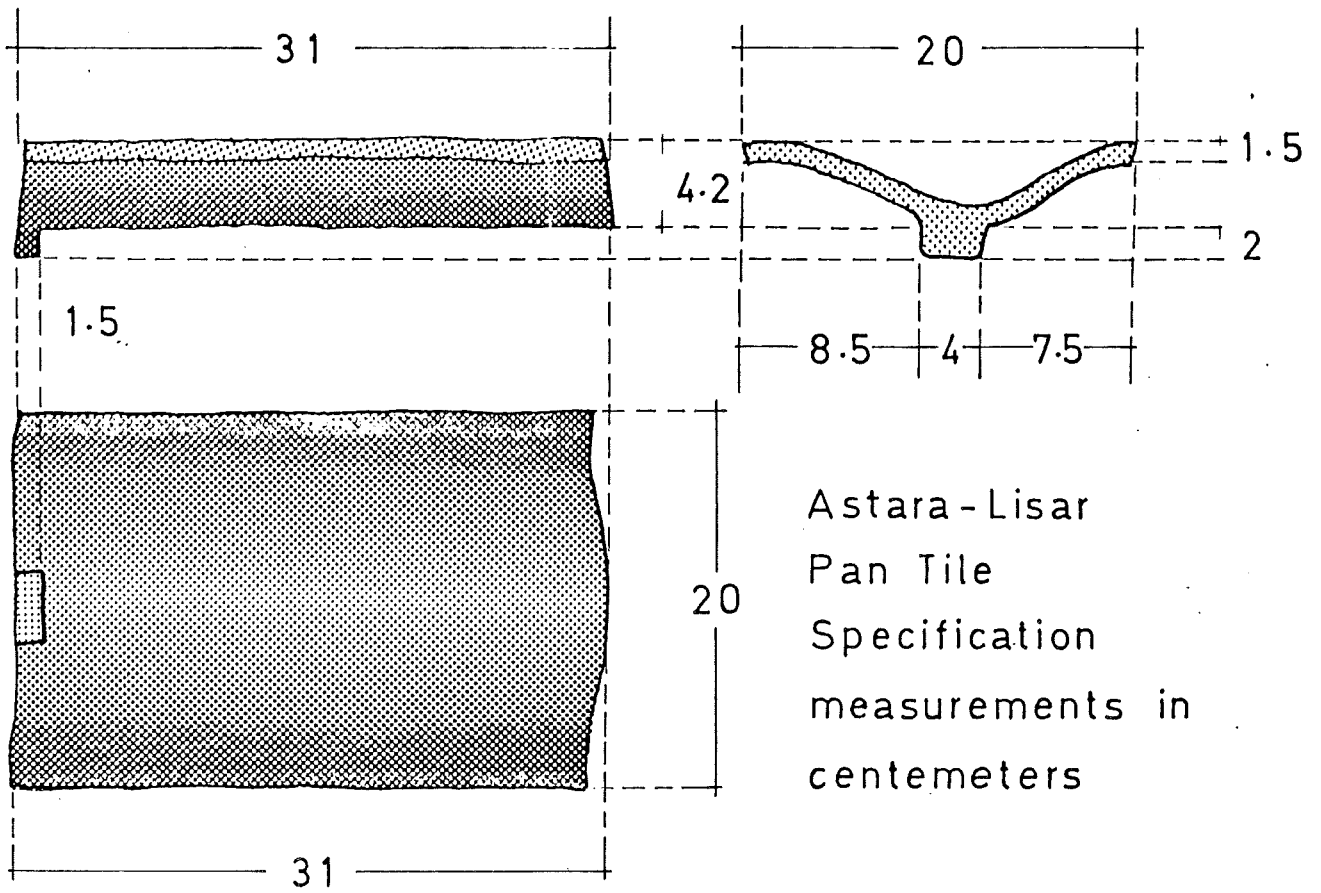

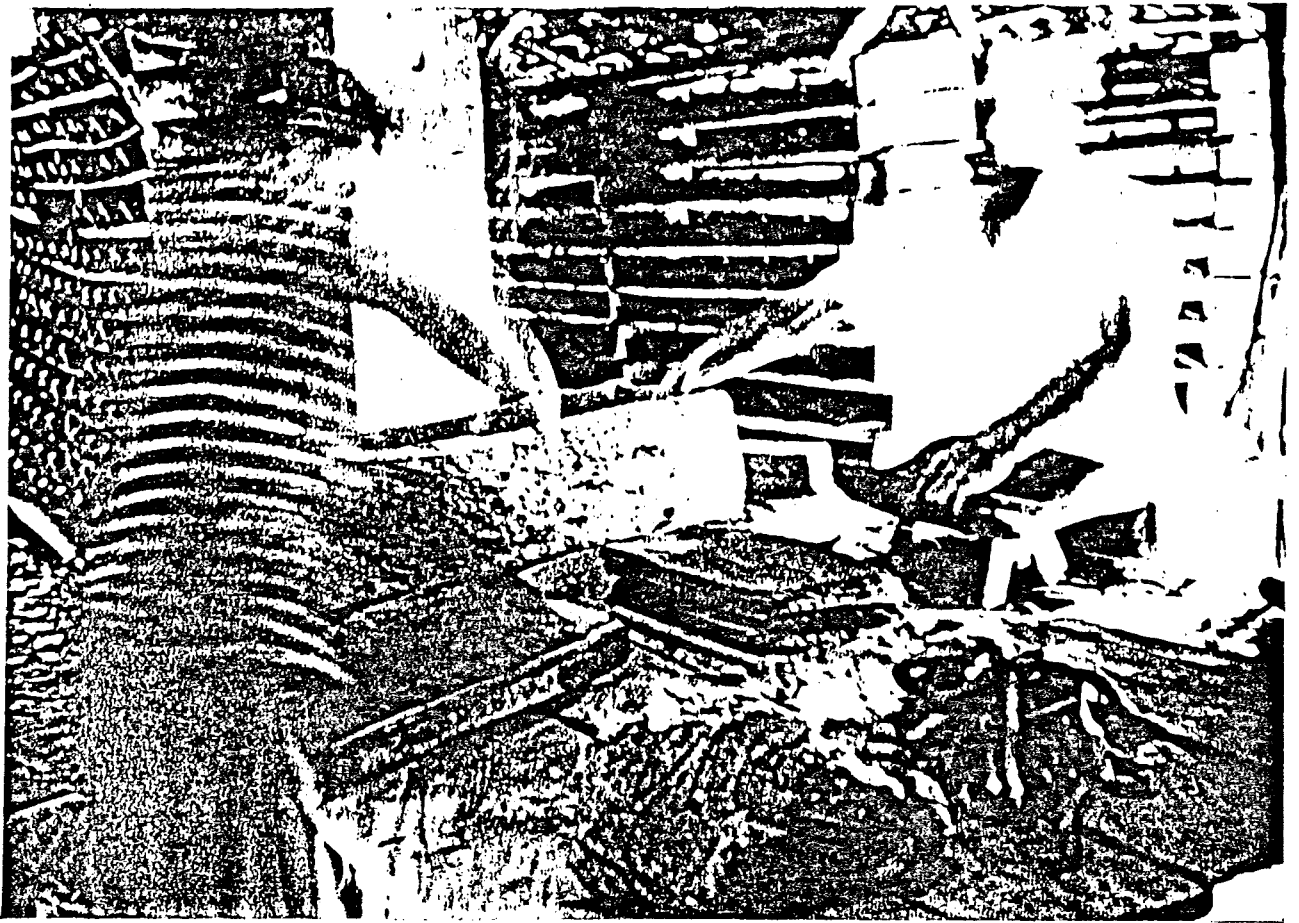

Hand molding process for pantiles.

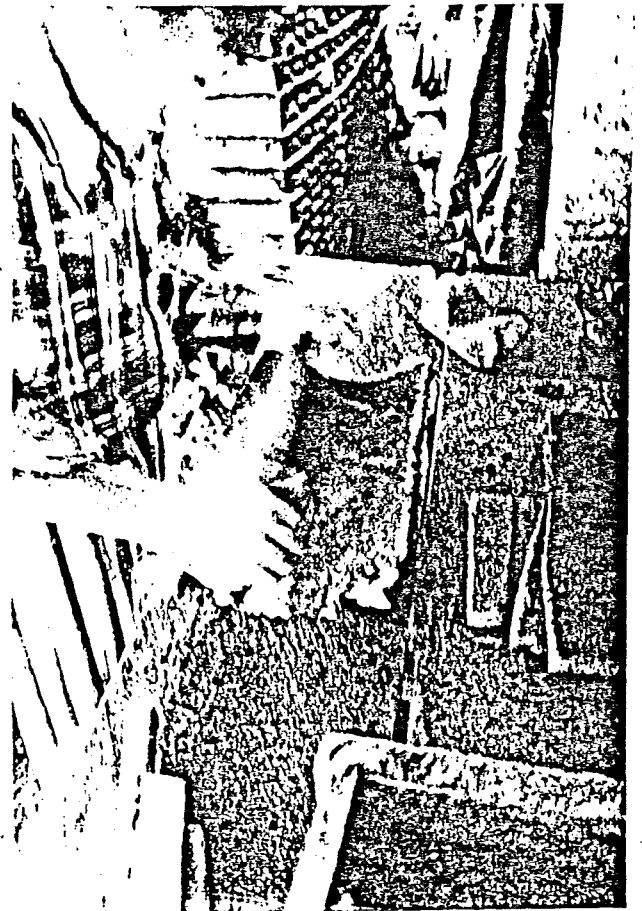

plement. A wooden platter, formed to correspond on one side to the curved profile of the tile, is placed over the fresh tile and the mould is then inverted. The mould is removed and the new tile is carried on the platter by the assistant to the drying racks.

Drying racks are open shelves about 12 cm. high. Each set of racks are approximately 2.5 metres long and could hold 132 tiles. Sheds such as those surveyed, measuring 25 m. in length by 8 m. wide, can hold more than 9000 tiles. The drying period is normally between two or three weeks.

The production unit studied had two drying sheds with their corresponding work spaces. A separate work team operates from each shed. Each team produces about 700 tiles per day, or about 80 per hour.

Tile moulding is usually contracted at a rate of 4000 rials per thousand to the "Ustad" who is usually responsible for the skilled work of actually moulding the units. He in turn pays a daily salary of 500 rials to the worker operating the clay mill, and 600 rials to his moulding assistant.

Once tiles have dried to about 8 to 10% moisture content, they become rigid and ready for firing. Tiles are transported to the kiln for firing. The accompanying drawing illustrates the various components of the kiln surveyed. The Chubar kiln's tile chamber measured about 3x4 m and 2 m. deep, and had a capacity of between 20 and 25 cubic metres; it can hold 7500 tiles per firing. Tiles are stacked on "end", a method allowing the free movement of hot gases around each tile during the baking process. The tile chamber is roofed over with a sheet metal pitched structure supported on brick columns. The firebox located under the tile chamber is vaulted with numerous perforations allowing access of heat and gases.

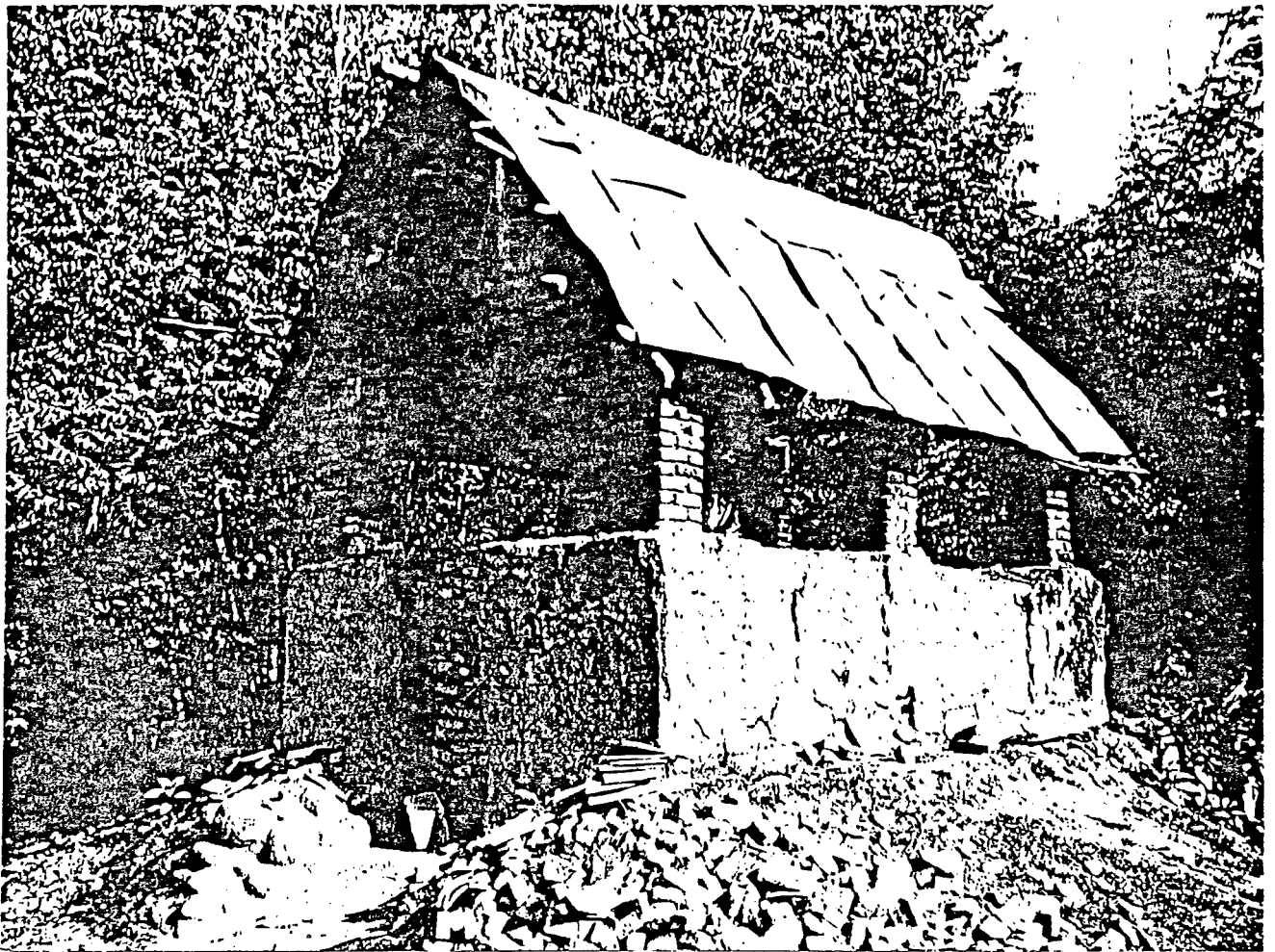

Chubar open top updraught kiln with capacity of 7500 tiles.

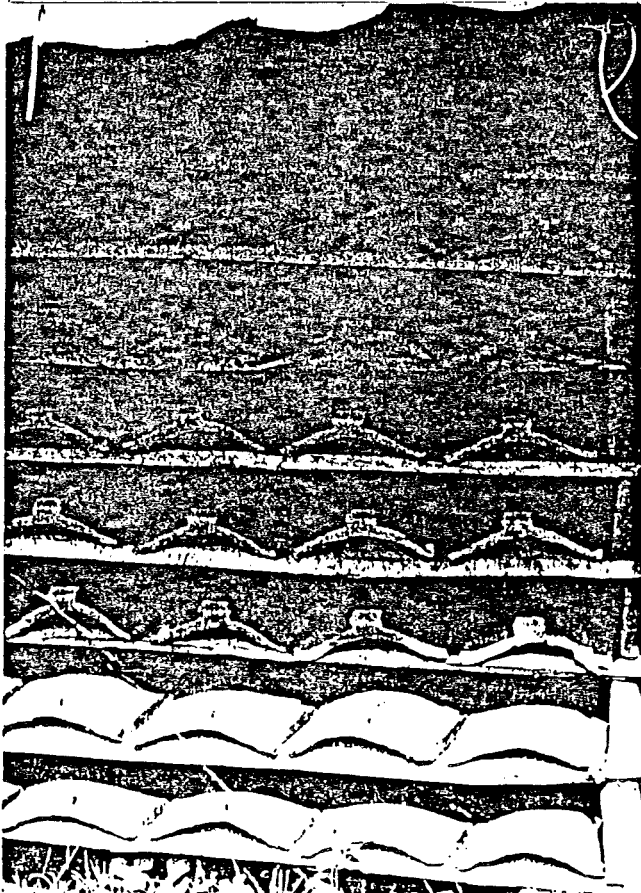

Unfired tiles drying on racks.



Storage method for fired pantiles.

Tile Kiln - section
Chubhar , Gilan

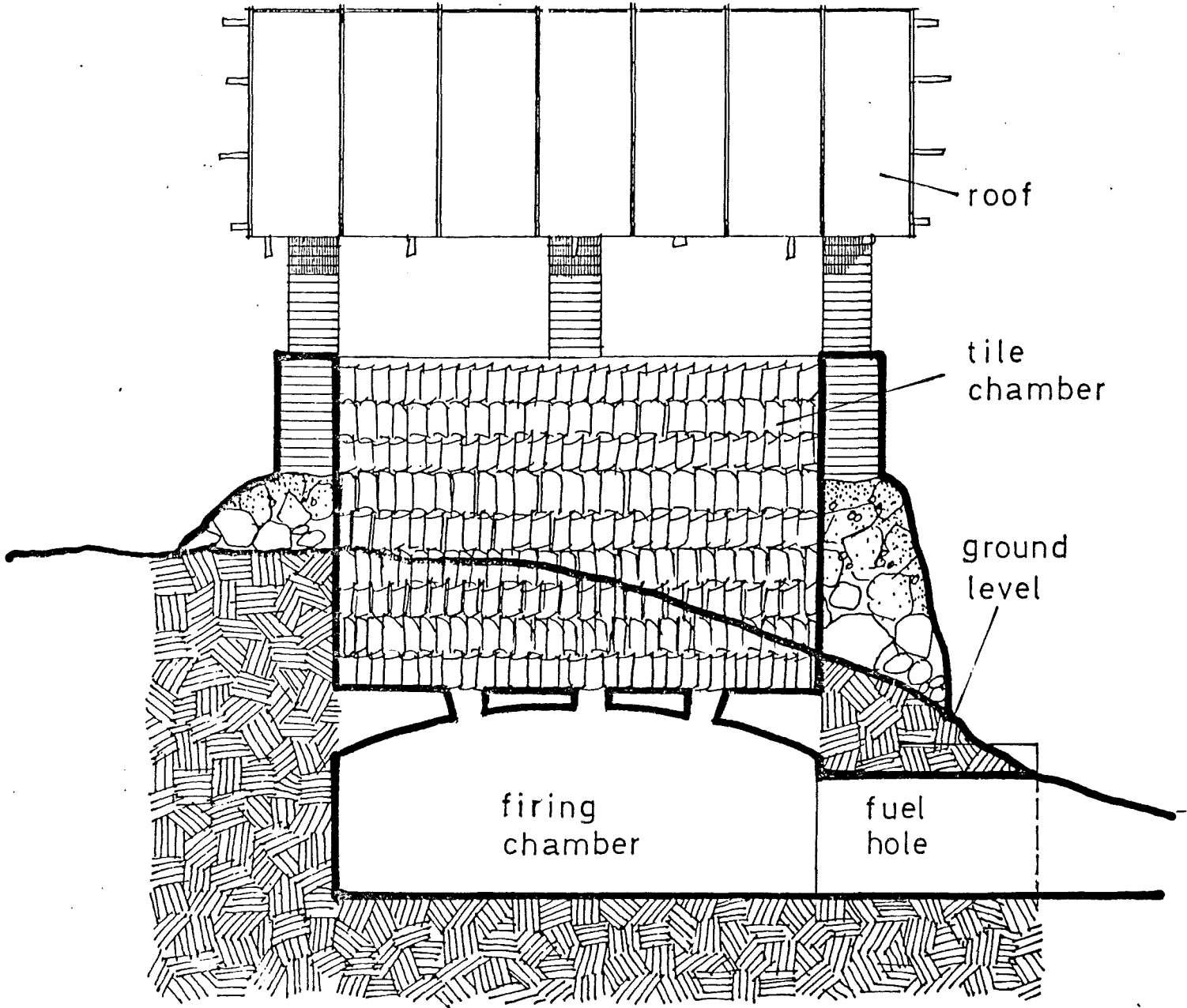

Tile Drying Racks

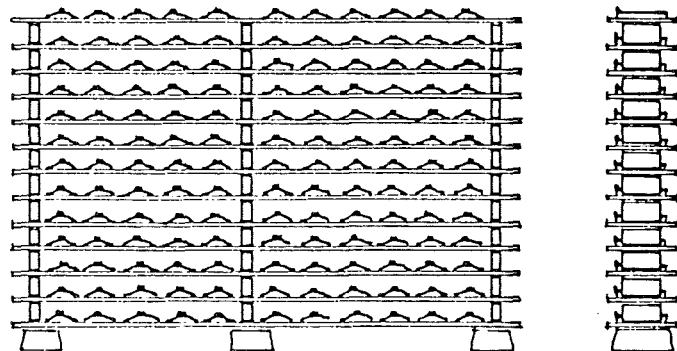

to the tiles being baked. The kiln is fired on wood which is loaded through the vaulted fuel hole at the base of the kiln. Wood fuel is stored near the mouth of the fuel hole. About 5000 rials of timber is consumed in each firing.

Loading of this kiln takes one day. The firing takes four days, followed by a day of cooling. Unloading takes another day. Altogether, batches of 7500 tiles can be produced every week. Workers on this kiln suggested that at this rate they were able to make more than twenty-five firings in the six month production season.

At the time of the survey, tiles were marketed at a cost of 9000 rials per 1000. Rapidly increasing labour costs have raised tile prices over the last three or four years from 3000 rials. Even at these high prices tile costs remain competitive with other roofing materials, and tile is the preferred roof covering for most of the Astara-Lisar region.

Neka-Behshar-Tile Industry:

The area of foothills and plain between Neka and Behshar has a large number of kilns producing principally red fired brick and lime. In the recent past, roof tile was also a major product. Not only the older parts of the towns of Neka and Behshar are roofed with red tile, but also the towns of the Sari plain to the west and Gorgan to the east. Between Neka and Sari tile is also the predominant rural roofing material.

Four or five tile kilns operated in the vicinity of Rostam Kola, about 9 km. west of Behshar. It is apparent that there is no problem of accessibility to good ceramic clay, since many of the kilns use onsite clay. Soil samples were collected at a kiln site in Rostam Kola for testing by the authors. The resulting analysis shows (as in the Chubar sample) a very high proportion of fine particles. The soil is primarily composed of fine silt particles at over 80%, and small quantities of clay and fine sand. Like the Chubar sample, the fine texture of the Rostam Kola soil makes it suitable for ceramic production.

The kiln studied was a small production unit, but could be considered typical of the few kilns operating within the town of Rostam Kola. The kiln site was in the south western part of the town, bordering on the garden areas at the edge of the town. The kiln site was a relatively self-contained unit with only fuel being brought from off the site. Clay is quarried on a site adjacent to the kiln and water is obtained from a well beside the working shed. The kiln studied operates as a family concern, only employing occasional village labour.

The type of tile produced, typical in this area and called

MECHANICAL ANALYSIS

LOCATION: Chub-bar , Gilan, Iran

SITE: tile kiln

DATE:

Granulometric Chart

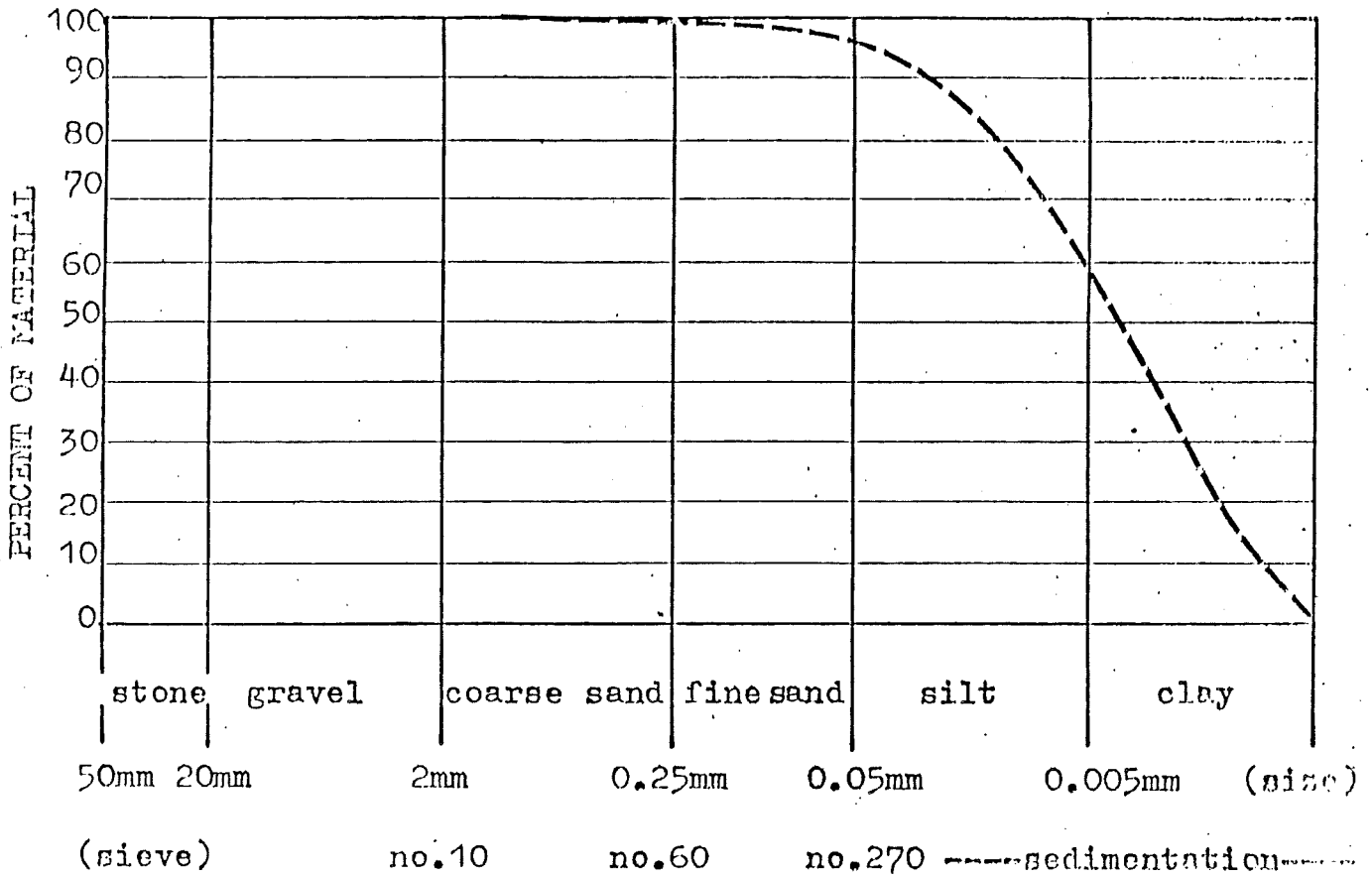

Particle Gradation

PARTICLE	mm SIZE	no. SIEVE	PER-CENT
Gravel	+2	10	0.00
Coarse Sand	+.25	60	0.35
Fine Sand	+.05	270	14.35
Silt	-.05	270	59.11
Clay	.005	sed.	26.30

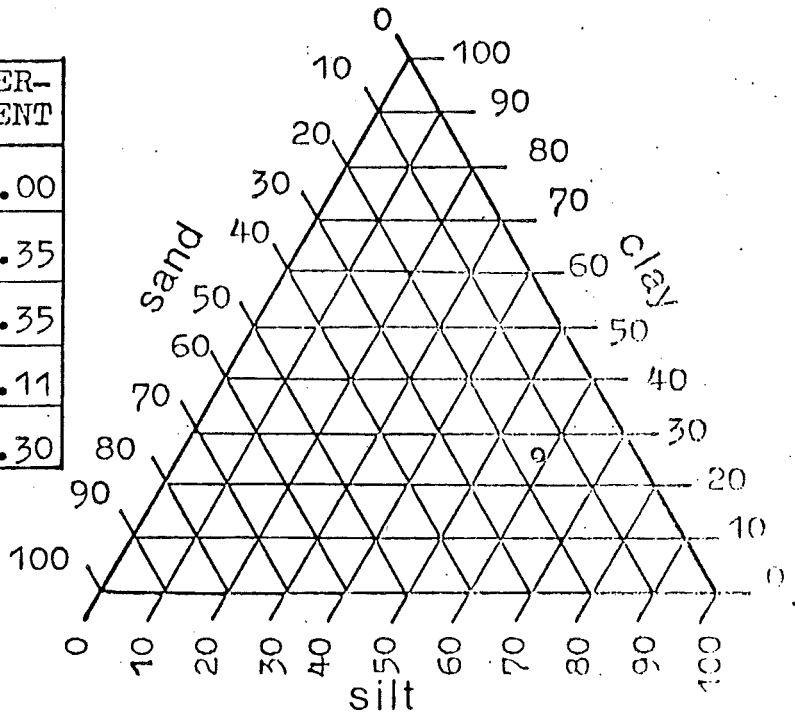

Soil Classification:

Clay-Silt

Classification Chart

locally "sofal", is a slightly tapered cylindrical double lap type, known in Europe as Spanish tile.

Production Method: Case Study B

Soil, after being excavated from the clay pit, is mixed manually by shovel with water to form a paste which is left to soak several days. During this process it is important for the clay to become thoroughly and uniformly saturated, and for lumps to be broken down. Kneading soil by foot is commonly practised. The clay in a plastic state is then carried to the working shed for forming into tile.

The drying shed work area is a long pitched roof shelter with walls of loosely woven branches. The nature of the walls allows for relatively free movement of air through to facilitate drying. At one end of the shelter is situated the work area, the main feature being the potter's wheel on which the tiles are formed. The wheel is situated in a shallow pit so that the potter can sit at ground level and use the floor of the shed as his working surface. Clay lumps of the appropriate size are placed within easy reach beside him. Each lump is first centred on the wheel. The wheel is rotated by a second disk fixed at a lower level and turned by foot. The potter with one hand forms the clay into a tapering cylinder, the other hand on the inside forms the hollow interior, as in pot or vase making. An assistant removes the cone from the wheel and sets it aside for drying. When "leather hard", the cylinder is wire cut longitudinally, thus forming two tiles. These are then set either on racks or on the floor of the shed to dry hard. Drying time may be somewhat less than that needed in the Astara-Lisar region because of the lower air humidity.

Tile / Brick Production Unit.
Rostam Kola , Mazandaran

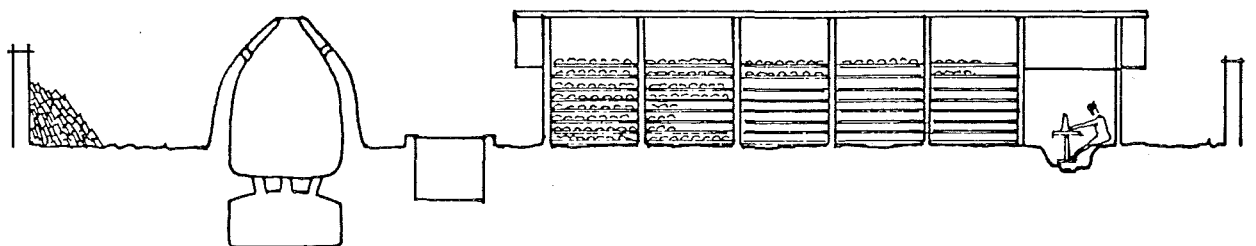
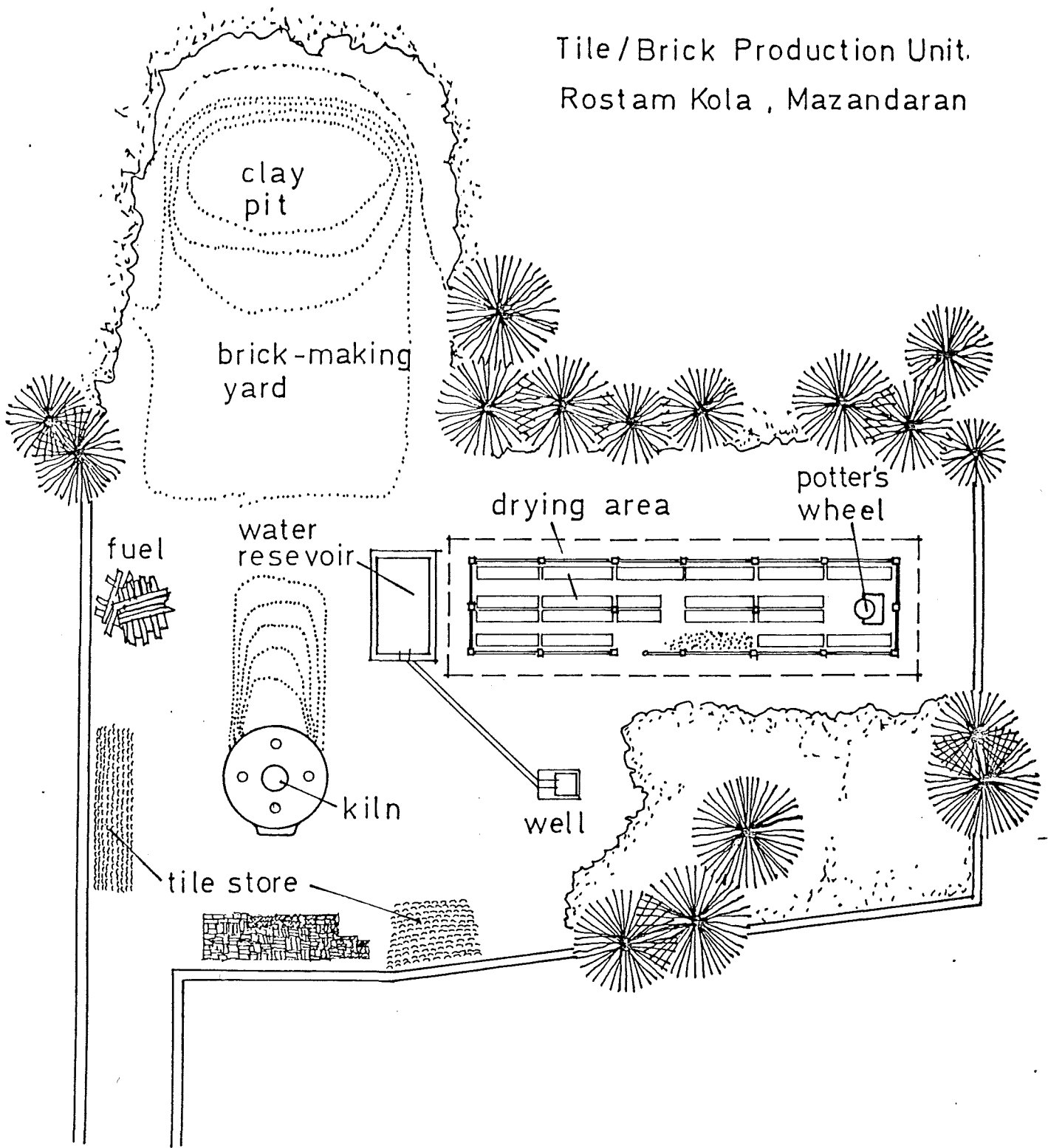

Tiles are afterwards transported to the kiln where they are stacked on end for firing.

The Rostam Kola kiln differs in design from the Chubar kiln. While the latter was open mouthed, allowing heat to escape freely from the tile chamber, the Rostam Kola kiln is tapered at the top and thus controls the outflow of heat and exhaust gases to some extent. For this reason efficiency can be expected to be higher. This kiln has been designed to be fired on wood, which is fed in via a ramp leading down to a fire hole at the kiln's base. Combustion takes place in the vaulted fire chamber and heat escapes through to the tile chamber through holes in its floor.

The kiln owner stated that three or four years ago when the kiln was last used for burning tile, wood was the fuel employed for firing. Twelve of thirteen horseloads of oak or elm wood were consumed each firing at the total cost of about 2500 rials. The kiln has since been converted to run on black oil. Each firing now requires three barrels of black oil, costing a total of 3300 rials.

The kiln had a capacity for seven to eight thousand tiles. Because of the time consuming tile forming technique one month was needed between firings to accumulate enough tiles to fill the kiln chamber. One day was required for laying tile in the kiln. The kiln was fired for forty-eight hours, then two or three days were needed for cooling and removal. By the described method a team of two people are able to produce about 600 cut tiles per day. In this kiln the principal tile maker was also the kiln owner and his wages came from profits of selling the finished tiles; they were calculated to be about 900 rials per day. His assistant, by current rates, would be paid between 400 and 600 rials per day.



Rostam Kola covered up draught kiln.

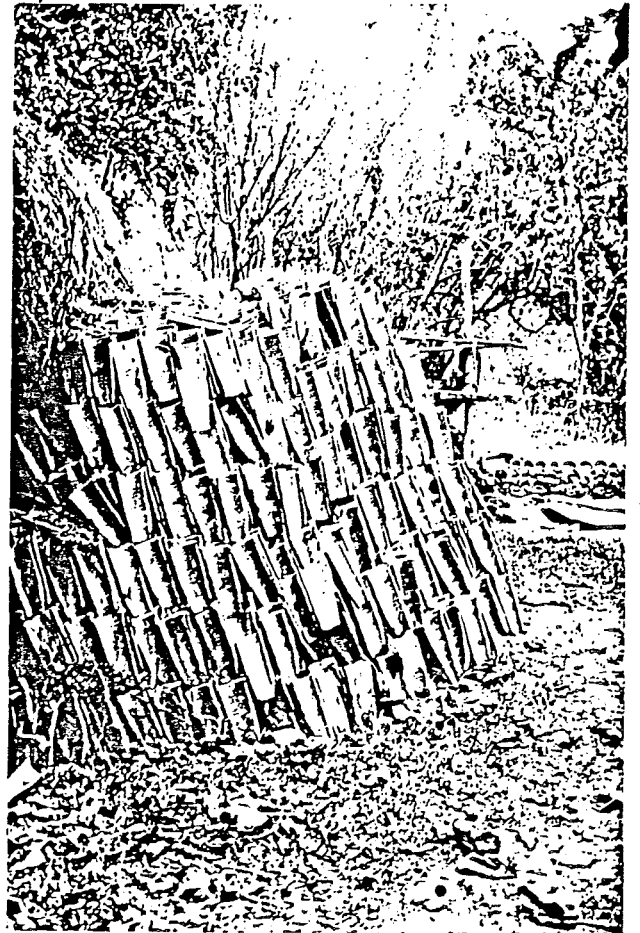

Tiles formed on potter's wheel. Method of storing fired tiles.

Like the Astara-Lisar district, tile production in the Neka-Behshar district is limited by the climate to a six month season, beginning in the spring and finishing with the early autumn rains. During this season the total production of the Rostam Kola kiln was less than 50,000 tiles.

Tile has not been produced by the Rostam Kola kiln for the last three or four years. The kiln has since been employed for brick production. The equipment still exists for tile production and there is still a stock of tile in storage within the yard. According to the owner and chief tile/brick maker, production could be switched back to tile at any time. Lack of demand and the increasing fashion for sheet metal roofing are the reasons given for the decline of tile in the region. In spite of this, local builders still maintain that tile is the superior roofing material in the region. There remains a demand for roofing tile and most of the new buildings currently under construction in Rostam Kola and neighbouring settlements use tile roofing. This demand is met mainly by recycled tiles from demolished buildings, and to a lesser extent from reserves still in storage with tile production units or materials merchants. Tiles are preferred over sheet metal roofing by many builders for environmental reasons. Attic spaces under tile roofs can be used as food stores during the winter months, whereas goods stored under metal roofs are susceptible to freezing. As well as this, recent increases in sheet metal roofing costs have brought the new material's price above the cost of recycled tile. This factor may account for the continued interest in the use of tile.

The market price for tile at the time of the survey was 2500 rials per thousand. This represents an almost four-fold increase in price since five years ago when tile sold for 700 rials per thousand. The prices given are from the

kiln site; to this must be added transportation costs, which correspond to about another 500 rials per 1000 for a distance of about 60 km.

The effects of increasing labour costs on a production system which is apparently over labour intensive has led to the decline of the tile industry in the Neka-Behshar region. If the Rostam Kola production unit can be accepted as typical, tile costs would have to be increased from the current 2500 rials per 1000 to about 4200 rials per 1000 to make the production method viable. At the higher price, wages of the workers could be paid at current market rates (autumn 1978) and an acceptable margin of profit could be made.

On the other hand, such an increase in the tile price would put tile well above the price of any competitive material, hence making it unmarketable.

If the tile industry were to be revived in the Neka-Behshar area, developments must be made in the production method. Since raw materials are plentiful, skills are available (although in need of upgrading), and a market apparently still exists, such a revitalization programme may be feasible.

Comparative Tile Production

	Chubar	Rostam Kola
Type of tile	Single Lap .20x.31m.	Double Lap .10x.24m.
Tiles per sq.m. of covered area*	31	100
Volume of tile cu.m./sq.m. of covered area	.0319	.0374
Dryweight of tile kg./sq.m. of covered area	51.6	60.5
Type of Kiln	open updraught	enclosed updraught
Capacity of Kiln	24 cu.m. 7500 tiles	7 cu. m. 7500 tiles
Number of firings per 6 month season	25	12
Yearly Tile Production	200,000	90,000
Yearly Production equivalent covered area, sq.m.	6,500	900
Employment	5	2
Consumer Cost per 1,000 tiles	9,000Rs. 15.0	2,500Rs. 4.17

* Note on areas

One square metre of horizontal covered area is taken as the standard for purposes of comparing different roof types. This unit has been calculated in each case to allow for different roof slopes.

Economic Comparison

	Chubar	Rostam Kola	
Raw Material Cost * /sq.m. of covered area	0.016	0.0	
Energy Costs in Firing /sq.m. of covered area	0.034	0.073	
% of Selling Price	7%	18%	
Workers' Salaries per day	500Rls. 600Rls. 1700Rls.	Given Salaries 400Rls. 900Rls.	Current Rates 500Rls. 1500Rls.
Labour Costs /sq.m. of covered area	0.207	0.344	.476
% of Selling Price	48%	82%	69%
Total Production Cost /sq.m. of covered area	0.257	0.417	0.549
Annual Profit as % of Selling Price	45%	0.0%	20%
Profits and Return /sq.m. of covered area	0.212	0.0	0.137
Selling Price to Consumer /sq.m. of covered area	0.469 Market Price	0.417 Market Price	0.686 Calculated Price

* Note on costs

The price of one labourer's work in one day (which at the time of the research was 600 rials) is taken as the basic unit of cost, and all costing figures given in the table are fractions and multiples of this unit. Since the prices of local materials in the Caspian area include a large labour component in production, this appears to be an appropriate unit. The labour unit maintains its comparative value over time as prices change.

Proposals:

A comparison of the production methods in the two tile regions of the Caspian points out their respective shortcomings and advantages. It can be seen that the major factor in production in both cases is the labour component. In the case of the Rostam Kola kiln, 82% of the materials cost is accounted for by labour. The small size of tiles produced in this area and the time consuming production process are reasons for this.

An increase in tile size is the simplest way of improving this situation. The recommended size for double lap tiles in Europe is 18. by 35. cm.* or more than 2½ times larger than those made in the Neka-Behshar area. These larger tiles would sell for a much higher price and would only require about the same labour as the smaller tile. However, the higher cost would be offset by the reduced number of tiles needed on the roof. The single lap tile produced in the Astara-Lisar region has distinct advantages over the double lap type. The single lap pan tile saves about 20% in required raw material and the resulting roof is correspondingly lighter, reducing construction requirements.

Partial mechanization of the tile moulding process would also decrease labour costs. Two basic methods could be adopted:

- i) Extrusion of a continuous tile profile, which is then cut to tile lengths.
- ii) Moulding by a pressing machine, which can be either manual or motor driven.

While hand made tiles are often irregular in size and shape, machine produced tiles are noted for their uniformity.

The Rostam Kola tile yard, it should be noted, does not

* A.J.Elder, A.J. Handbook of Building Enclosure, 1974, p. 10

employ a clay mill. Manually mixed clay lacks the uniform quality necessary for good tile making. Power driven milling machines can produce large quantities of clay of the proper consistency in a short time.

LABOUR FOR THE MANUFACTURE OF ROOFING TILES *

Process	Plain tiles				Single-lap tiles			
	Handmade 80 tons/week		Extruded 250 tons/week		Handmade 80 tons/week		Extruded but pressed 250 tons/week	
	Men	Man-hours per ton	Men	Man-hours per ton	Men	Man-hours per ton	Men	Man-hours per ton
Hand-winning and haulage including weathering.....	6	3.0	—	—	6	3.0	—	—
Excavator winning and weathering rope haulage	—	—	4	0.6	—	—	4	0.6
Wet pan	1	0.5	1	0.2	1	0.5	1	0.2
Clot production.....	1	0.5	1	0.2	1	0.5	1	0.2
Souring	1	0.5	—	—	1	0.5	—	—
Barrowing clots to makers	1	0.5	—	—	1	0.5	—	—
Making	—	—	4	0.6	—	—	8	1.3
Hand-moulding and setting in racks	10	5.0	—	—	16	8.0	—	—
Drying on racks	1	0.5	—	—	3	1.5	—	—
Placing pallets in ascender	—	—	—	—	—	—	2	0.3
Wheeling to dryer	—	—	6	1.0	—	—	1	0.2
Cambering and chequering	—	—	6	1.0	—	—	—	—
Loading and wheeling ..	2	1.0	4	0.6	2	1.0	4	0.6
Setting	2	1.0	4	0.6	2	1.0	4	0.6
Firing--continuous	—	—	3	0.7	—	—	—	—
or intermittent	4	2.8	—	—	4	2.8	9	2.0
Drawing and sorting ...	2	1.0	4	0.6	2	1.0	4	0.6
Wheeling and stacking ..	1	0.5	3	0.5	1	0.5	3	0.5
Loading	1	0.5	3	0.5	1	0.5	3	0.5
TOTAL	33	17.3	43	7.1	41	21.3	44	7.6

Capital costs for both tile moulding machines and clay mills are quite high, and large investments in such equipment may not be feasible in the small production yards one

* H.W.H. West, The Establishment of the Brick & Tile Industry in Developing Countries, 1969, p.107.

finds in the Caspian. Increased use of capital intensive methods would no doubt lead to the centralization of the tile industry into larger production units. Centralizing production would tend to take the industry out of the rural region and remove an important source of rural employment.

Rationalization of the tile making process is possible without destroying its employment generating potential.

It can be seen from the plans of both the Chubar and the Rostam Kola tile yards that placement of the elements, such as the work areas, drying racks, and kilns are in a random fashion. A great deal of time and labour is wasted in transporting the clay to the work area, or the tile to the drying racks and then to the kiln. Additionally, because the firing process requires several days for unloading and cooling, tiles can not be fired continuously. Also, because of the intermittent nature of the firing process, requiring periodic labour inputs, there is little specialization of production activities. The production method can be rationalized by improved site organization and better management of labour.

The accompanying diagram shows a proposed layout for an upgraded tile production site. Two kilns, fired alternately, are employed so that tiles are being constantly burned. Elements such as the clay mill and drying racks are positioned so as to cut down transportation distances. A manual production method similar to the Chubar one is employed, so that the essential employment generating aspect of the process is not lost. However, a higher degree of specialization means that the tile moulder or his assistant need not leave their work periodically to help load or unload the kiln. It is assumed that their production level will therefore increase. A new specialized role, that of the kiln keeper is created. The kiln keeper is responsible for the skilled

Improved tile Production Unit
Showing Rationalized Layout

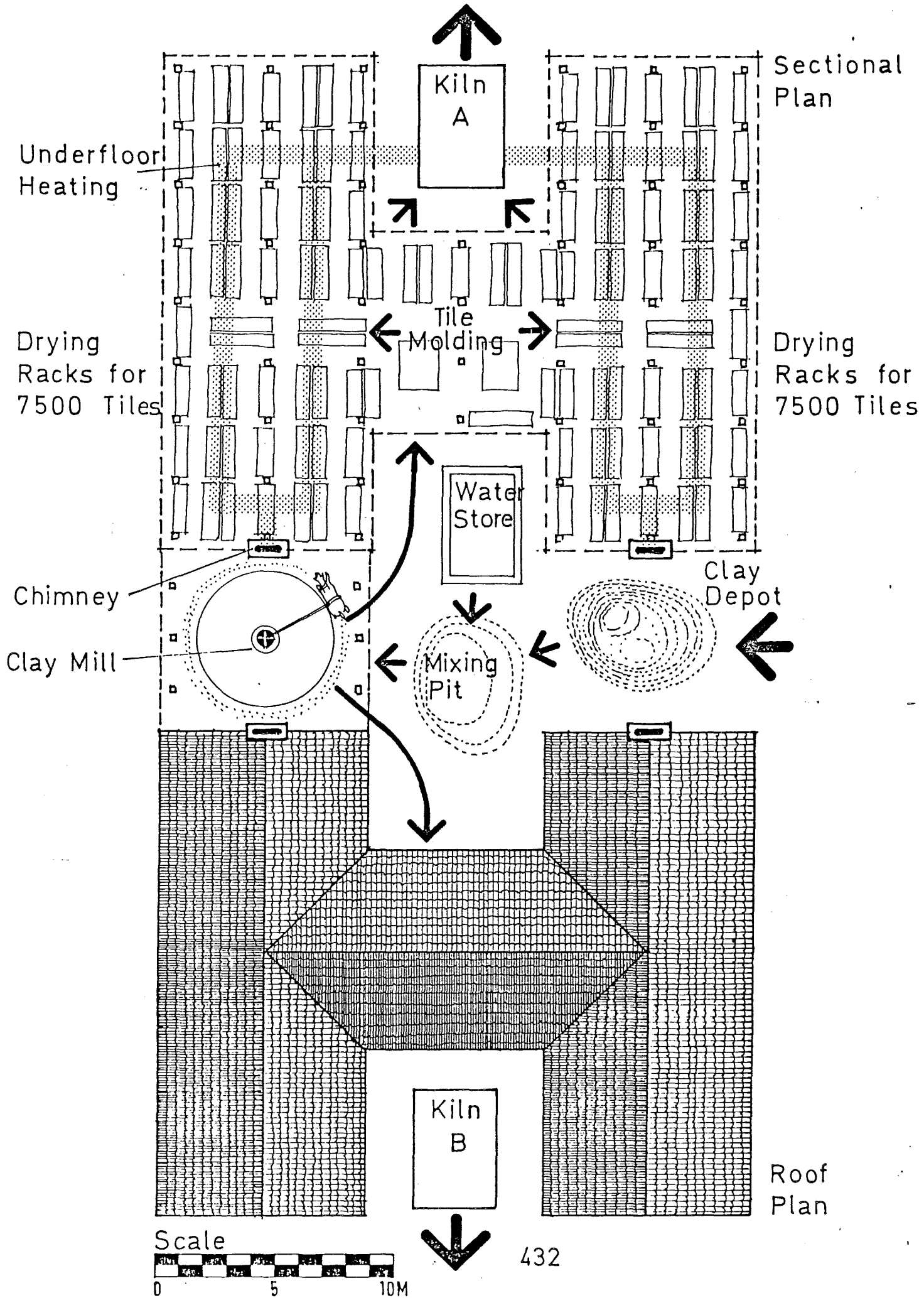

task of supervising the laying of the kiln and maintaining the firing at the optimum level. Deliveries of materials and pickup of the finished products are also organised to be more efficient.

Assuming production and firing methods similar to those employed already in Chubar, the improved layout and job allocation method suggested above could result in about 27% increase in efficiency.

Further recommendations are made in the following pages for improving drying methods and kiln design, and for extending the production season beyond the present six months. These improvements could lead to a further increase in efficiency and production.

Traditional Tile Production System

From the Chubar Kiln

(Output 7,500 tiles per week)

	Sunday	Monday	Tuesday	wednesday	Thursday	Holiday	Saturday	Sunday	Monday	Tuesday	wednesday	Thursday	Holiday	Saturday	Wage in Rls.
Kiln Schedule		f	→	c	u		f	→	c	u	
Tile Maker 1		f	Moulding				m		f	Moulding				m	1500
Assistant 1		f	Stacking				u		f	Stacking				u	600
Tile Maker 2	Moulding.....			→					→					1500
Assistant 2	Measuring and Stacking.....			→					→					600
Mill Worker	Milling.....			→			u	Milling.....			→			u	500
Total Labour Cost														4700	

- | | | | |
|---|--------------|-------------------------------------------------------------------------------------|----------------|
| | Loading Kiln | u | Unloading Kiln |
| f | Firing Kiln | m | Moulding Tile |
| c | Cooling |  | Holiday |

Improved Tile Production Unit

Labour Organization and Kiln Firing Schedule

(Output 15,000 tiles per week)

	Sunday	Monday	Tuesday	Wednesday	Thursday	Friday	Saturday	Sunday	Monday	Tuesday	Wednesday	Thursday	Friday	Saturday	Daily wage in rials
Kiln A	l	f	→	c	u	l	f	→	c	u	Daily wage in rials
Kiln B	→	c	u	l	f	→	c	u	l	f	
Kiln Keeper	A	A	B	B	B		A	A	A	B	B	B		A	1000
Kiln Worker	A	M	B	B	M		A	A	M	B	B	M		A	500
Mill Worker	Operate Clay Mill											→	500	
Tile Maker 1	Moulding Tile for Kiln A											→	1500	
Assistant 1	Measuring Clay and Stacking											→	600	
Tile Maker 2	Moulding Tile for Kiln B											→	1500	
Assistant 2	Measuring Clay and Stacking											→	600	
Apprentice	Moulding Tile Alternately for Kiln A&B											800	
Total Labour Cost														7000	

- l Loading Kiln
- f Firing Kiln
- c Cooling
- u Unloading Kiln
- A Kiln A
- B Kiln B
- M Mixing
-  Holiday

Kiln Design and Firing:

Kilns are normally required to bring temperatures of ceramic products to between 900°C. and 1100°C in order to cause particle fusion in the baking process. These temperatures must be maintained for a period of time in order that products are thoroughly and evenly fired.

Kilns can vary widely in design, firing method, size and fuel. All these factors have an effect on efficiency and quality of products.

The simplest way of firing tiles is by constructing a temporary "clamp". This method does not require a permanent kiln structure at all. Tiles are simply stacked up and packed around and over with straw, wood or dried dung. The clamp is fired and covered over with ashes or coals to bake the tiles. This method does not produce uniform results as many tiles are under or over fired. Such methods have not been noted by the authors in Iran, although it is common practise in Northern India and Nepal.

Updraught Kilns.

Updraught kilns are the common type for tile production in the Caspian. Updraught kilns are based on a simple design consisting of a tile holding chamber fired from another chamber immediately below, where fuel is burned. There are two types of updraught kilns observed in the Caspian area. The first, an open top type, was found in the Chubar area. Tiles were stacked to the brim of this kiln and left open, to be fired with only a pitched roof rain shelter as a chimney. Hot gases are free to move around the tiles being fired and then escape into the atmosphere. Escaping gases may have temperatures of as high as 800°C. and as much as 50% of the

heat input may be lost in these gases. For this reason such kilns are relatively inefficient in fuel consumption.

The second type of updraught kiln was studied in Rostam Kola. This kiln shows in principle an improvement in design. The tile chamber in this case was enclosed by a dome, except for small openings in the top which allowed gases to escape. Although temperatures of the exhaust may have been similar to the Chubar kiln, gases escape at a controlled rate. Despite the fact that there was no chance to compare the two kilns' firing efficiencies, the Rostam Kola unit should prove to be somewhat better.

Downdraught and horizontal Kilns

Downdraught tile kilns were not noted in the Caspian region but are employed sometimes in brick production. Traditional wood burning downdraught and horizontal kilns have been used in Iran in Khorassan for firing pottery. Such kilns could be easily adapted to fire tile in the Caspian region. This firing method is considerably more efficient than the one commonly used now. Combustion gases first rise through the stacked tile to the vaulted ceiling and then are forced to descend to ground level in order to escape through chimney openings. The speed of exhaust is considerably reduced through the downdraught and the tile is able to draw more heat from the gases. Therefore fuel consumption is substantially lower in downdraught kilns than the commonly used kilns today.

Continuous Kilns

In continuous kilns the process of firing is not interrupted. At any one time unfired tiles are being loaded and finished tiles are being withdrawn, while fuel is being constantly

fed and tiles are being fired. Exhaust gases before being lost to the atmosphere are channelled to dry and preheat the freshly loaded unfired tiles. This process makes very effective use of heat energy and has proven to require only a half to a quarter of the fuel needed by conventional intermittently fired kilns. These kilns, however, require high initial capital investments and must be operated on a large scale. They are only efficient to operate at a high production level of about 100,000 tiles per week, and are therefore not suitable for small scale production.

Drying

While fuel costs can be reduced by more efficient kiln design, heat energy is still lost in great quantities through waste gases. A further 30 to 40% of input heat is contained in the tile and kiln structure at the end of the firing to be lost to the atmosphere in cooling. This waste heat can be recovered and used for drying the freshly moulded tiles or preheating tiles about to be fired.

An underfloor heating system could be incorporated into drying sheds so that energy could be withdrawn from waste exhaust gases and used for drying the tiles. Tiles which are dried more efficiently, in turn require less fuel in the firing process.

One of the principal problems of tile production in the Caspian is the climate, which limits tile making to six months. Supplementary heating to work areas and tile drying racks could help extend the production season into or throughout the winter, enabling annual output to be virtually doubled. This of course would only be favourable if market demand exists locally or tiles could be transported easily to neighbouring regions.

Fuels

Wood is the indigenous fuel for tile in the Caspian region. Its use today is still widespread, particularly in small scale production. The use of oil as a kiln fuel is on the increase and is presently used in most large kilns. Even small kilns, like the one studied at Rostam Kola, have been converted to run on black oil in recent years.

Forest hardwoods have in the past proved to be a cheap and readily available source of fuel. Because wood is an organic material, it can, unlike most other fuels, be regenerated and with proper management a continuous supply can be assured. Local woods such as oak are excellent fuels having high calorific values. The quality of wood as a fuel is greatly dependent upon its moisture content. Green or freshly cut wood normally has a moisture content of 25% or more. Green oak wood has a corresponding calorific value of 2×10^9 calories per cubic metre, or almost 8 million BTU's; whereas air dried oak having a moisture content of 12 to 15% will produce about 2.4×10^9 calories per cubic metre, or about 9.5 million BTU's per cubic metre, which is about 19% more heat. Completely dried wood, although rarely used, will have a correspondingly greater calorific value. It can therefore be seen that by properly drying wood considerable savings can be made in fuel costs.*

One cubic metre of air dried oak is enough fuel to fire about 1325 tiles of the Chubar type at existing kiln efficiencies. Wood burns with a clean flame, having a low ash content of .3 to .6% and can produce kiln temperatures of up to 1000°C., suitable for firing both tile and brick.

The principal disadvantage of wood is its bulk. One cubic metre of wood is equivalent in heat to 334 litres of oil.

* Portola Institute, Energy Primer, 1974, p.155.

Although only about twice the volume of coal per unit of heat, wood burning kilns need large firing chambers and a considerable amount of labour is required for firing.

New Fuels

Although coal is mined in Iran, its use was not noted in tile or brick kilns in the Caspian. Oil has proven to be the alternative fuel to firewood.

Traditional kilns have been easily converted from solid fuels to heavy oil burning. The common method involved the introduction of a manually adjusted drip feed from small 200 litre oil drums. The rate of flow, and hence the kiln firing temperature, varies with the level of oil in the drum. Frequent manual alterations of the tap setting are required to maintain a constant feed rate which is necessary to properly regulate temperatures. Regulated fuel injection and pre heating systems can improve the efficiency of oil firing.

Liquid fuels have certain advantages over solid fuels for tile and brick burning. Labour is saved in handling fuels and also in time required for cleaning the kiln and removing ashes after firing. Oil, unlike wood and coal, is uniform in quality and resulting products tend to be fired more uniformly.

The disadvantage of fuels such as heavy oil is its cost, which is dependent upon external prices and market conditions. It also needs a well established distribution system which is not always available in more remote rural areas. Wood which is unsuitable for construction purposes can be used readily as fuel. Local availability of timber means a constant supply of fuel is ensured, and as mentioned earlier, wood is a renewable resource.

Alternative fuels such as wood chips and rice husks can, by themselves or in mixture with other fuels, be employed in kiln firing. These fuels are considered generally to be low-grade. Special firing chambers could be designed to efficiently utilize these fuels. Because in the Caspian these are often waste products, they are readily available and can be employed at very low costs.*

* H.W.H. West, op.cit.