

Woodless Construction

Construction sans Bois

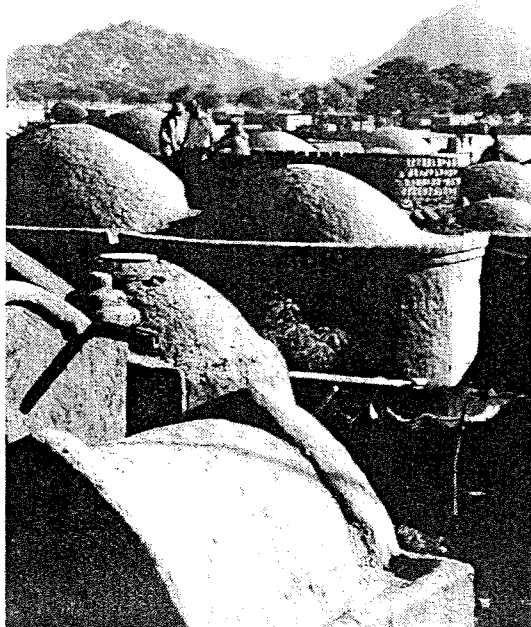

Development Workshop

B.P. 13, 82110 Lauzerte, France

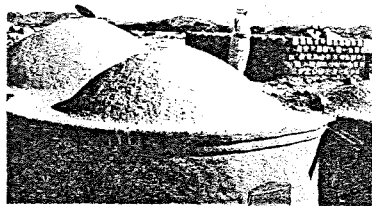
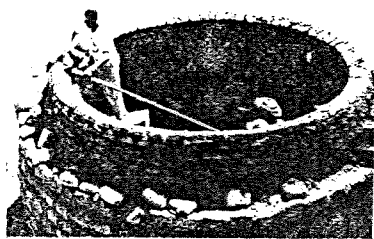

'Woodless Construction' is the term by which a building system which includes using vaults and domes in unstabilized mud brick has come to be known in a number of countries of the Sahel since its introduction to Niger in 1980.

Woodless Construction can provide a solution to a wide range of housing and public infrastructure needs in many arid or semi-arid regions of the world.

It was introduced to Niger initially as a response to the increasing scarcity of "traditional" building materials (i.e. wood, branches, grasses), which results in a problem which has both a human dimension (how to meet shelter needs) and an environmental dimension (how to reduce the consumption of organic materials in the precarious ecological balance of the Sahel).

In these illustrated information sheets, you will find background information and basic technical information not only about the building technology itself - which has proved to be economically viable and capable of being assimilated rapidly into the local building "vernacular" tradition - but also about the process of introducing it in such a way that it has a real chance of being spontaneously replicated, i.e. after external financial and technical assistance has ceased.

The document is available in English and French, and includes a list of further publications and a video-cassette available from:

Development Workshop, B.P.13, 82110 Lauzerte, France.

Par "Construction sans Bois", nous entendons un système de construction comprenant des voûtes et coupoles en terre crue non-stabilisée qui fut introduit au Niger en 1980 et qui est maintenant connu sous ce nom en plusieurs pays du Sahel.

Ce système constructif peut répondre à une large gamme de besoins en habitations et en équipements publics en beaucoup de régions arides ou semi-arides du monde.

Il fut introduit au Niger pour tenter de répondre à la pénurie de matériaux "traditionnels" pour la construction (trunks d'arbres, branches, chaume), qui donne lieu à un problème qui a à la fois une dimension humaine (comment faire face aux besoins en abri) et une dimension environnementale (comment réduire la consommation de matériaux végétaux dans le précaire équilibre écologique du Sahel).

Ces fiches illustrées expliquent non seulement l'histoire de cette technologie et ses principales caractéristiques techniques - technologie qui s'est avérée viable sur le plan économique et capable d'être assimilée dans le "vocabulaire" de la construction locale - mais aussi le processus grâce auquel il a été introduit pour faciliter au maximum ses chances d'être spontanément répliqué, c'est à dire quand les apports financiers et techniques de l'extérieur sont épuisés.

Ce document est publié en français et en anglais et comprend une liste d'autres publications et d'une cassette vidéo disponibles auprès de:

Development Workshop, B.P.13, 82100 Lauzerte, France.

Information sheets

- A** **What is 'Woodless Construction'?**
- B** **Vaults and domes - basic techniques**
- C** **Vaults and domes - architectural profile**
- D** **Using unstabilized earth to build**
- E** **How much do vaults and domes cost?**
- F** **Vaults and domes - problems to avoid**
- G** **Will vaults and domes suit your area?**
- H** **Introducing vaults and domes to your area**
- I** **For further information or help...**

- DW** **Development Workshop**

What is 'Woodless Construction'?

Background

In 1980, an integrated rural development programme working in southern Niger, (ISAID's "Tapis Vert" project in Chikal), became aware of how difficult it was to obtain the organic materials used locally for building purposes, and in particular wood for the flat roofs of mud brick houses.

The project invited Development Workshop to introduce a building system requiring no wood for the roofs, i.e. vaults and domes in unstabilized mud bricks, through a builders' training programme.

Subsequently, the Air-Ténéré Project for the Conservation and Management of Natural Resources run jointly by IUCN/WWF and the Government of Niger took up these same building techniques. Why?

On the one hand, the Project wanted to meet its own infrastructure requirements - including its headquarters in Iférouane - without resorting to wood as a building material. And on the other hand, it hoped that the building system might help to provide a solution to the local population's difficulties in building their homes.

The "woodless" Project buildings aroused widespread interest amongst local people and masons, as well as government representatives, reinforcing the Project's view that it should promote Woodless Construction as part of its activities.

The Project went on to fund training programmes, technical research, and dissemination of the building techniques, as well as the construction of numerous buildings, until 1990.

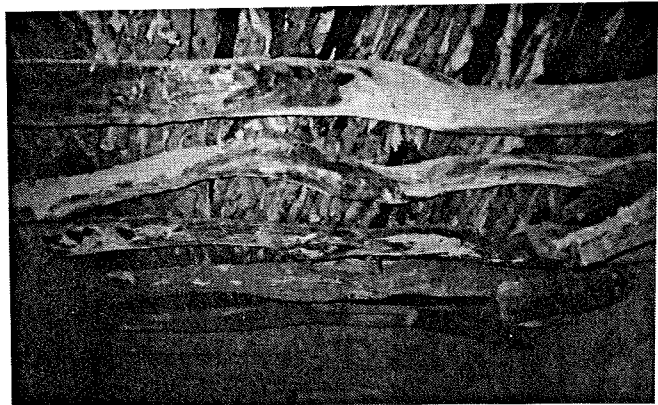

flat roof of a mud brick house - requiring enormous consumption of wood...



dome built of unstabilized mud brick - requiring no wood ...

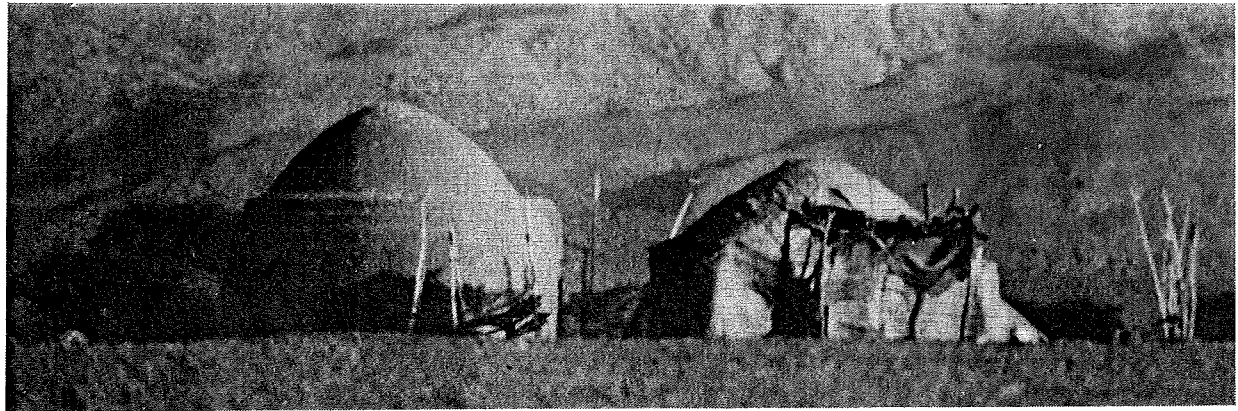

simple round domed shelter, built entirely from unstabilized mud bricks; its shape is reminiscent of that of the traditional tent (éhan) built from organic materials...

The human dimension: the problem from the point of view of the people.

Most families in developing countries will use whatever materials they can most easily obtain and use, or which they can afford, to build their homes. A simple shelter with mud brick walls and a flat roof made from logs and branches covered with earth, is in many parts of the world a cheap and straightforward building system, even if its performance (from the point of view of comfort, hygiene, durability, etc.) may be poor. But it is a system which is becoming more difficult -

- the price of wood is going up (and in some countries you need an expensive permit to cut down certain species);
- good quality wood is often very hard to find where it was abundant before;
- to obtain supplies of wood, people are having to travel further or resort to imports.

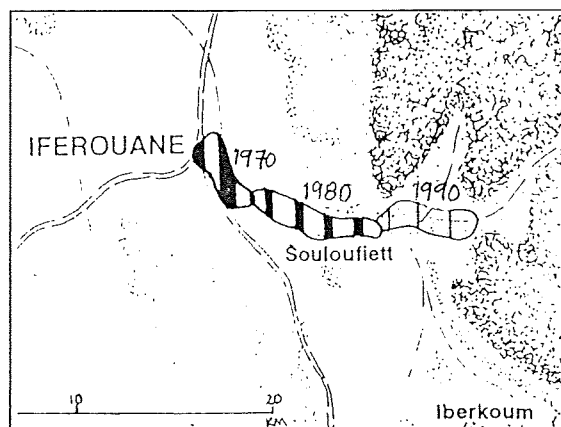

People are forced to change the way they build: we have observed in the Sahel examples as follows:

- rooms are becoming narrower because there is a shortage of long beams;
- a central pillar is used, reducing useable space.

how far do people have to go - often on foot - to find good wood?

the example above shows the regression of the doum palm (H. Thebaica) in the area of Iférouane, northern Niger:

in 1970 it was abundant in the immediate area of the village; by 1990, scarce supplies are to be found 12 to 18 kms away...

Many new houses are waiting to be roofed; many organic material roofs which would normally have been maintained or replaced are being left to deteriorate.

The environmental dimension: the problem from the point of view of the authorities and agencies.

All the countries of the Sahel are committed to combatting desertification and in this context government authorities and aid agencies are seeking to :

- reduce the consumption of wood and organic materials and thus -
- slow the disappearance of certain species and environmental degradation.

They also have other objectives:

- encouraging the use of local building materials;
- reducing crippling expensive imports of building materials or the energy needed to produce them;
- promoting healthy and comfortable homes which the population can afford and efficient public buildings.



'traditional' construction of a mosque (Niger) -

the dome rests on a structure of curved beams; small twigs are arranged on the top of the columns waiting to receive straight beams which will then be covered with small branches and finally earth.

woodless construction of a small rectangular domed shelter (Niger) -

the walls are in unstabilized mud bricks with a mud mortar; the dome is built without shuttering from smaller unstabilized mud bricks; the building will be finished with a mud render .

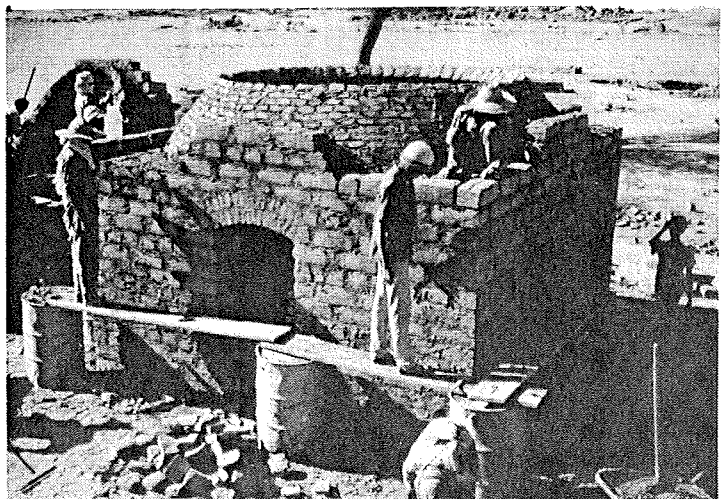

The facts

After more than 12 years' field work we are confident that -

- there is a genuine and growing demand for Woodless Construction;
- unstabilized mud brick vaults and domes provide a viable roofing system and are gradually being integrated into the local building "vernacular" in certain areas of Niger and Mali; they remain, however, insufficiently well-known and sometimes misunderstood.

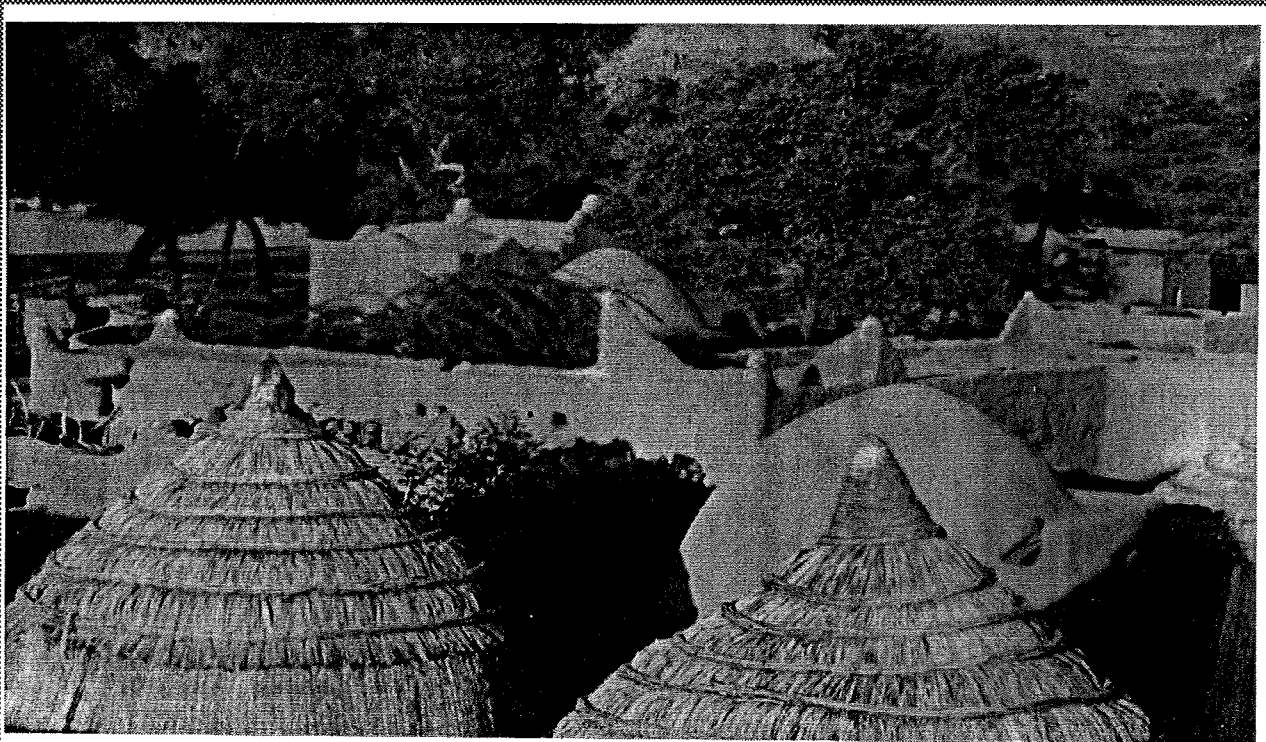

a changing roovescape - woodless vaults and domes alongside "traditional" flat roofs (with wooden beams) and straw huts in Iférouane, (Niger)

Promoting Woodless Construction

The facts point the way forward:

- the public, at all levels, needs to be made more aware and better informed;
- builders' training must continue and increase;
- there is a need for specific training for technicians and site supervisors;
- an appropriate system of quality control for design and construction must be set up;
- post-training technical assistance and follow-up is required.

These are now the immediate objectives of the Woodless Construction programme.

Vaults and domes - basic techniques

Where do they come from?

Vaults and domes built without shuttering have their roots in a long tradition of building in the arid areas of the Middle East. With very little wood available, over the centuries the masons of present-day Iran and Egypt developed this solution of building with earth as a way of meeting their shelter needs, from palaces to simple houses. There are many variations of the techniques, including so-called "Nubian" vaults and domes which emerged in the arid region of the ancient Nile valley kingdom and which were the subject of renewed interest in the 20th century, to a large extent thanks to the efforts of the famous Egyptian architect, Hassan Fathy.

Why use them elsewhere?

The dry conditions which gave rise to these techniques are today not dissimilar to those which prevail in most of countries of the Sahel, and indeed in many other arid and semi-arid regions of the world. Taking one country as an example, Development Workshop, (with many years' practical experience of the techniques, including in New Gournia with Hassan Fathy,) introduced Nubian vaults and domes to Niger in 1980 in a builders' training programme in Chikal. Subsequently, a programme for the conservation and management of natural resources in the Air-Ténéré region to the north of the country chose not only to use, but also to promote, the Nubian techniques for (amongst others) the following reasons:

- they are relatively easy to master;
- they are perfectly suited to building with unstabilized mud bricks;
- domes, and to a lesser extent vaults, are familiar throughout the Sahel, and can be seen - but with wood supporting structures - in palaces, mosques and private homes, as well as in granaries and round grass huts.

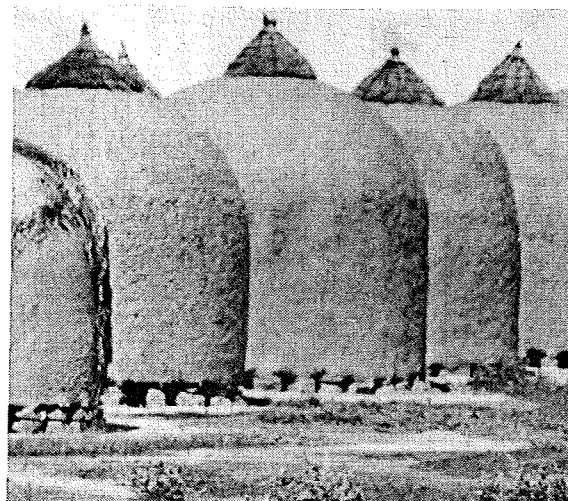

domes are a familiar sight throughout the Sahel, particularly on the thin "coiled" walls of granaries...

The Nubian dome

Horizontal, concentric courses of unstabilized mud bricks are laid first at a shallow angle and then more sharply inclined at one goes higher and towards the centre.

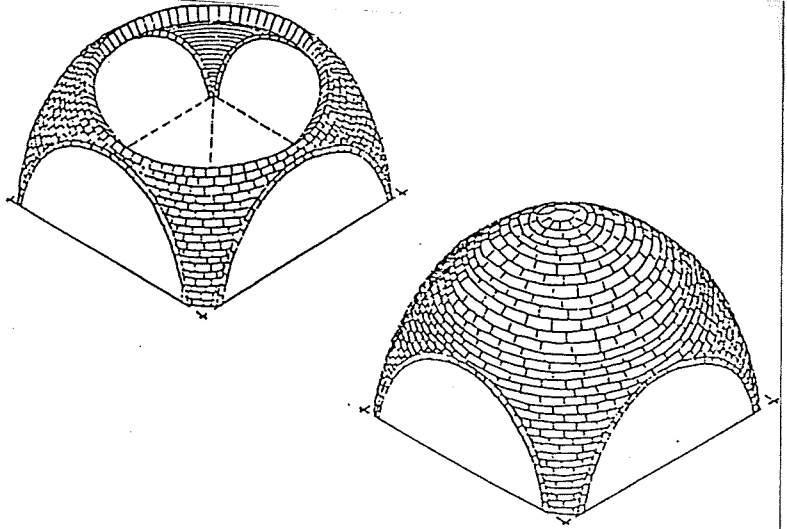

The position and the angle of each brick is shown by a wire or a radial arm (shown here) which rotates around a central post.



Single domes can cover square as well as round spaces. Several domes together, or a combination of domes and vaults, can be used to create varied and interesting forms and interior spaces.

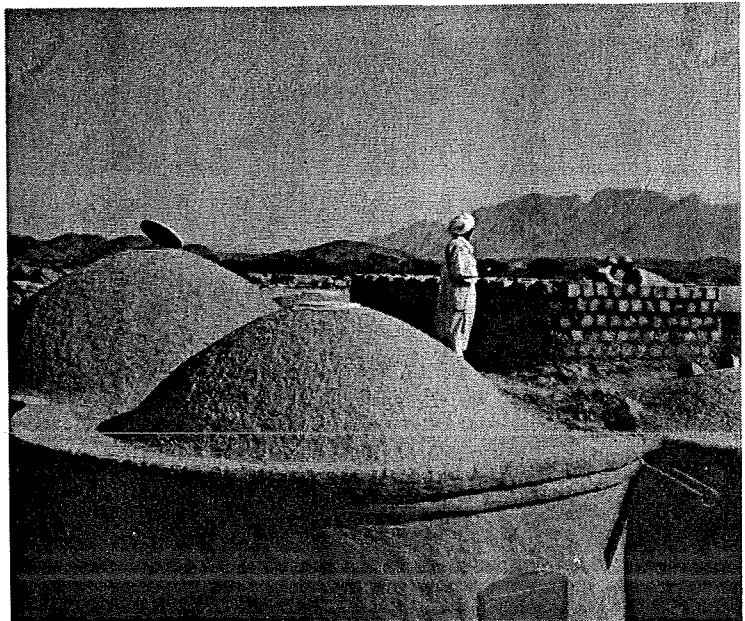

The Nubian vault

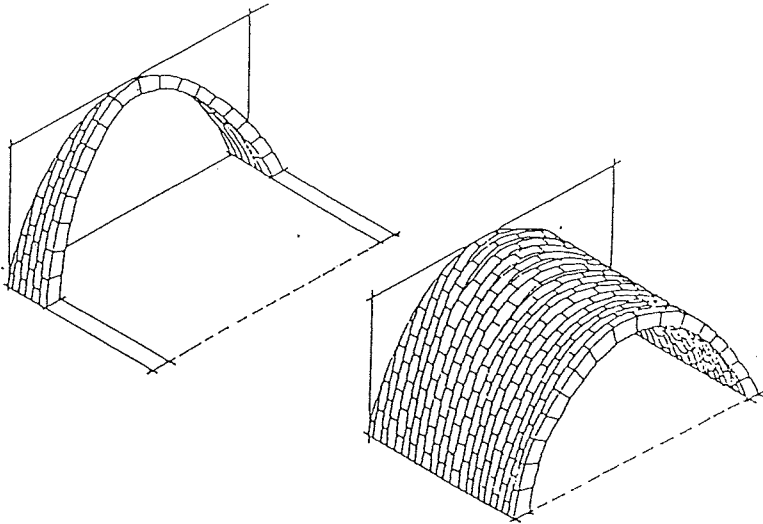

The vault, in the form of an inverted parabolic curve, is built up in vertical courses which are inclined towards a supporting wall.

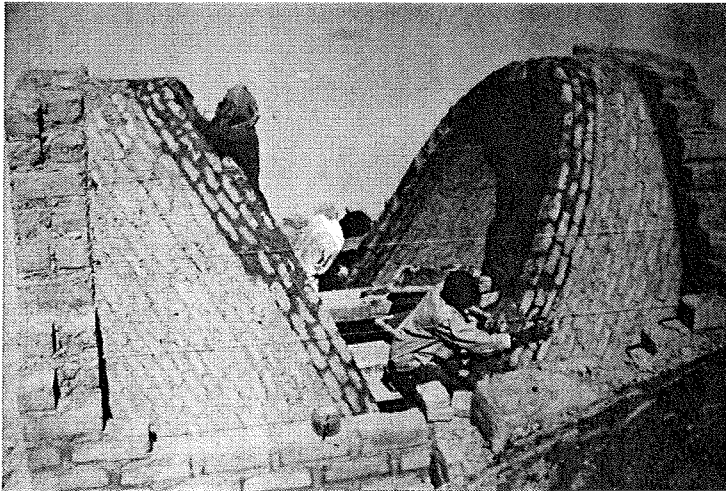

Thanks to the shape of the vault and the inclination of the courses, the bricks remain in place during construction without shuttering.

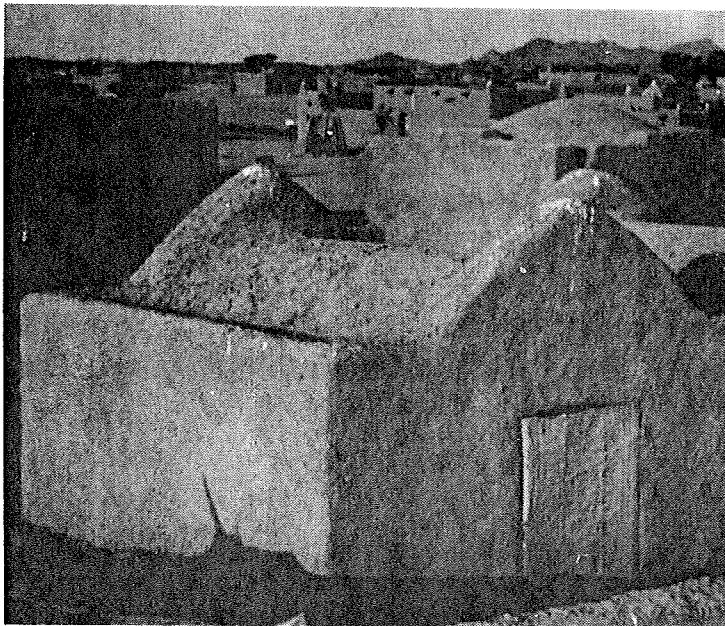

Vaults tend to be used to cover rectangular spaces. Several vaults of widely differing heights and spans can be combined with highly effective results.

A "south-south" technology transfer which makes sense

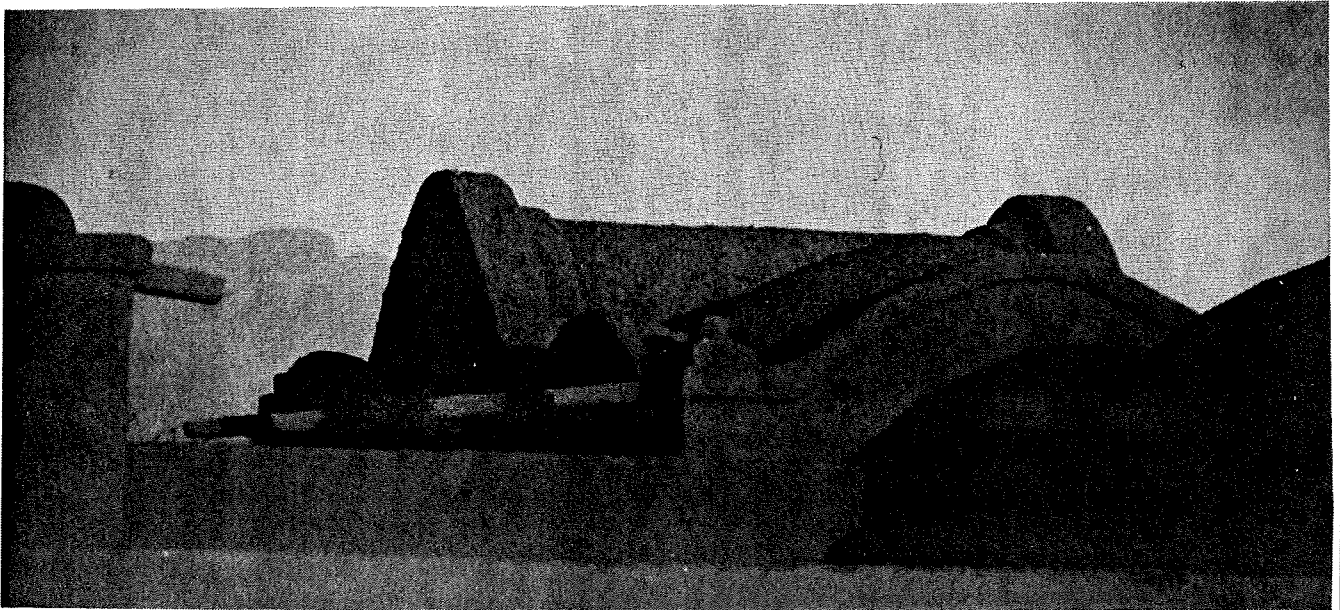

Introducing these "new" methods for building roofs in unstabilized mud bricks, without using any wood (even for shuttering) makes sense in many regions of Africa (and other parts of the world) for the following reasons:

- where the techniques are suited to local conditions and to the resources which are available, they are genuinely accessible to the whole population and can be rapidly assimilated by local masons;
- they can be used to build simple shelters and houses when the organic materials (wood, straw, etc.) traditionally used by people building their own homes are no longer easily found;
- they can equally be used for larger public buildings meeting high standards of comfort and cleanliness and responding well to modern needs;
- they stimulate local economies at national and village level and develop local skills by using the materials and masons at the core of the existing building process; this is particularly significant for public buildings, often heavily dependent on imported materials and external skills;
- they help to reduce imports (of building materials or the energy resources needed to produce them) which are crippling the economies of many developing countries;
- they are highly labour-intensive, and require - in their simplest form - no special equipment; this makes them well-suited to countries with large under-employed labour forces and little capital available for investment.

Vaults and domes - architectural profile

Architectural diversity

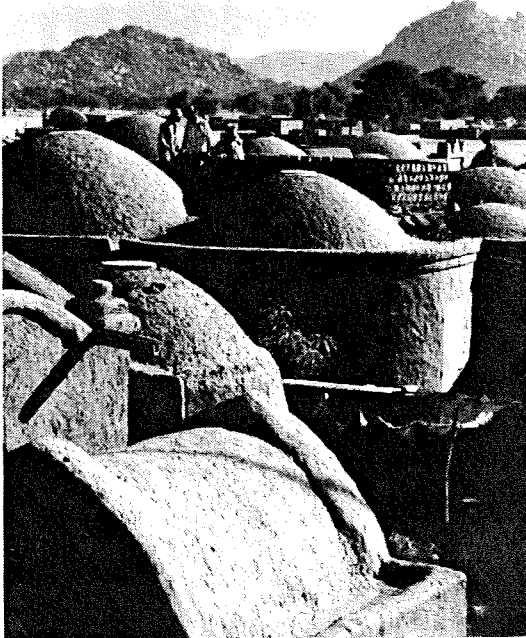

Vaults tend to be used to cover rectangular spaces.

Domes can be used to cover spaces of widely differing shapes and sizes (usually round or rectangular).

Several vaults and/or domes can be used in simple or more complex combinations to give very varied shapes and spaces.

Nubian vaults and domes can easily cover surprisingly wide spans. Trained village builders with minimal equipment have recently built 6m diameter domes and a 4.4m wide vaulted meeting hall in Iférouane (Niger). With experience, much greater spans are achievable.

Thanks to this inherent architectural flexibility, vaults and domes in unstabilized mud brick can be used for:

- simple (one or two-room) houses;
- more sophisticated private villas;
- public buildings (offices, clinics, mosques, cooperatives, etc.);

Bioclimatic advantage

Thanks to the thermal inertia of massive earth walls, outside temperatures are only very slowly transmitted through the walls and the roof to the inside. This is especially advantageous where there is a wide diurnal temperature range: the buildings stay cooler during the day than most comparable buildings using "modern" materials or flat roofs. (Similarly, they remain warmer at night during winter months - an especially important consideration for poor families.) This inherent advantage combined with bioclimatic design principles, (orientation and shading of openings, natural ventilation, interior courtyards, etc.), give comfortable interior living or working conditions, without recourse to air-conditioning or artificial ventilation. In a recently completed vault and dome office building in Niger, the temperature in the basement computer room remained around 30°C, even when outside temperatures rose to 47°C.

Esthetic flexibility

The wide range of shapes and finishings possible lend themselves readily to adaptation to local, or even individual, styles and tastes, facilitating their integration into the local vernacular building tradition.

From small, simple shelters and homes ...

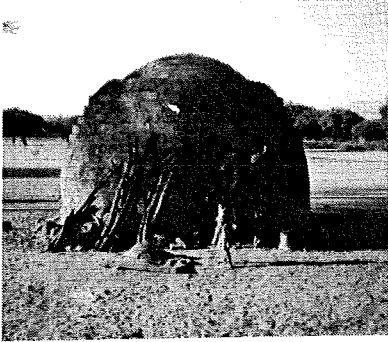

simple shelter - one of several built as a training exercise and donated to a destitute widow (Iférouane, Niger).

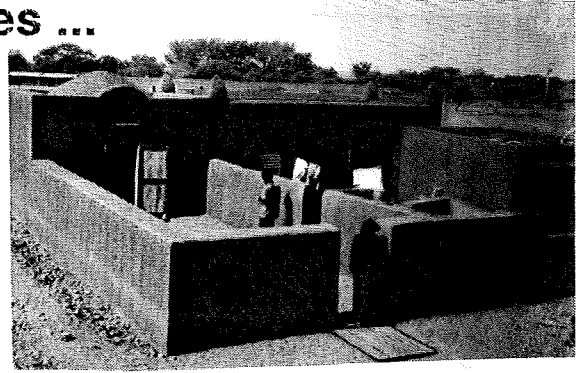

the owner-builder of this typical flat-roofed house (built with wood) chose to use a domed roof for an extension (Tchirozerine, Niger).

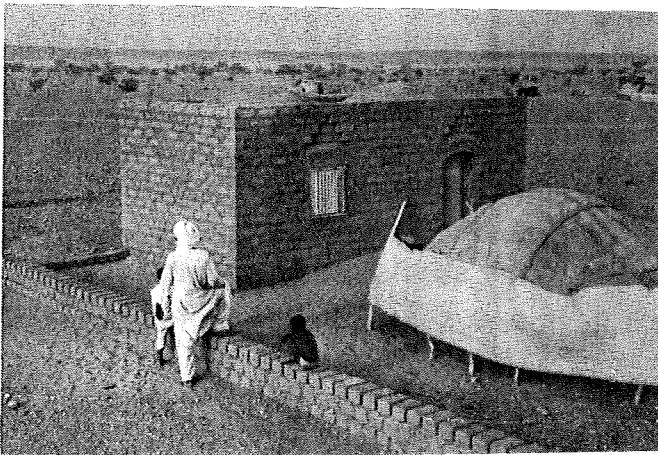

two-room domed house built by mason for his own family with no external financial or technical support (Tchirozerine, Niger).

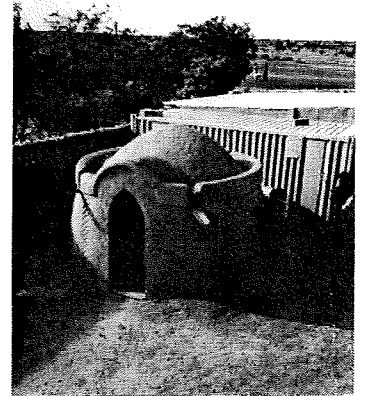

nightwatchman's shelter: the builder's choice of finishing provides a good example of local assimilation (Dosso, Niger).

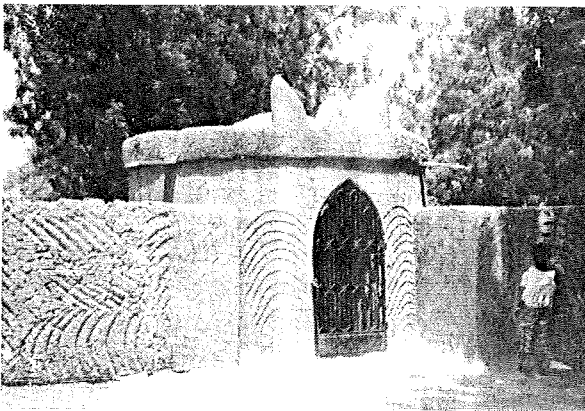

a traditional decorative render gives this small building "local colour" (Dosso, Niger).

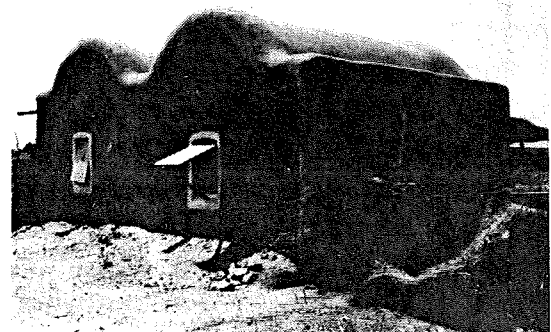

unusually, here the poor quality of the local soil justified a small addition of cement to the roof and the most exposed façade.

... to larger, more complex and sophisticated buildings -

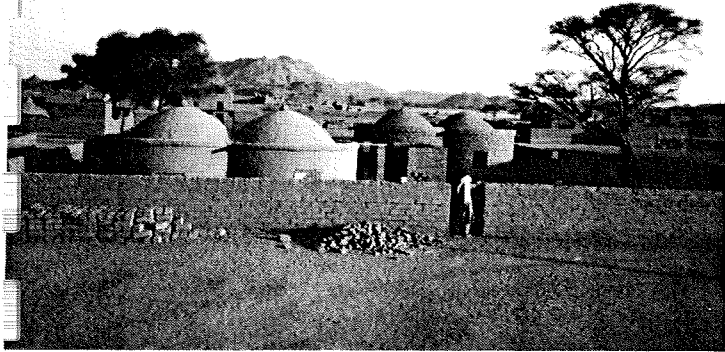

domed rooms, built by the son of a trained mason with his father's help (Iférouane, Niger).

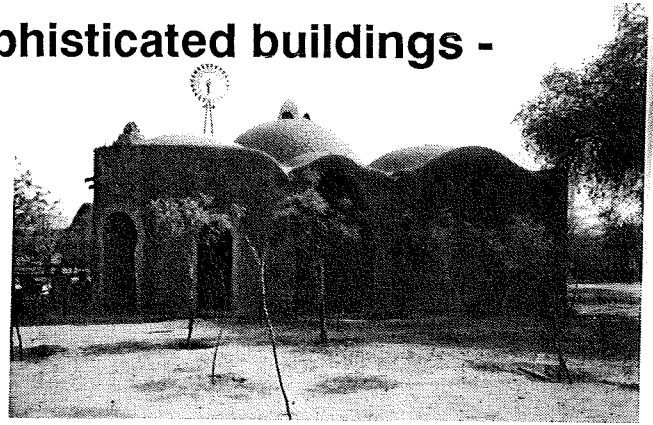

project office building (Chikal, Niger).

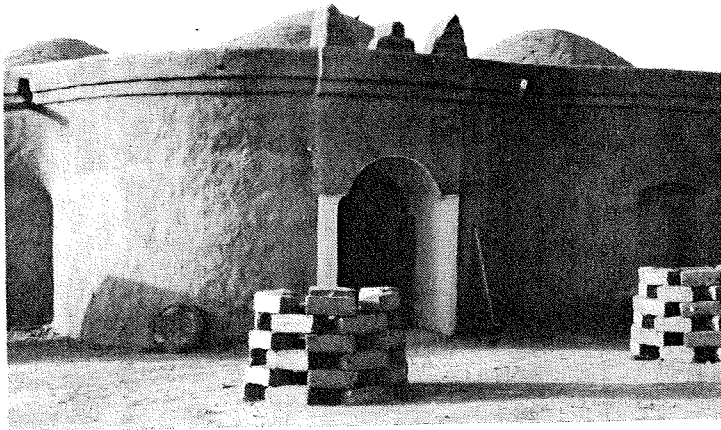

more sophisticated 9-room private villa commissioned from a local mason by a secondary school teacher (Iférouane, Niger).

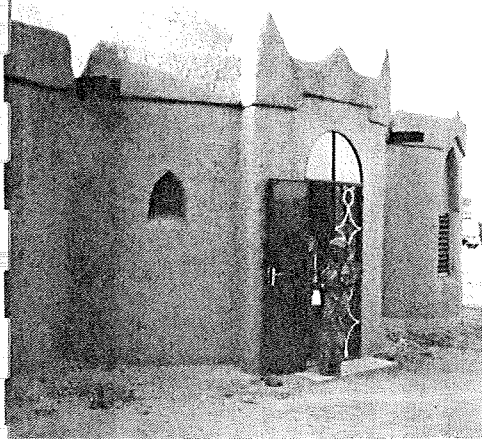
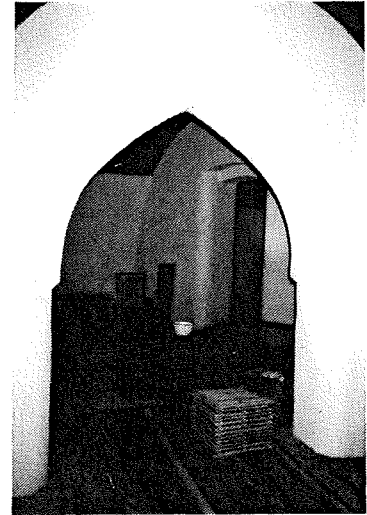

crafts centre in Agadez (Niger): simple structure with good quality finishings

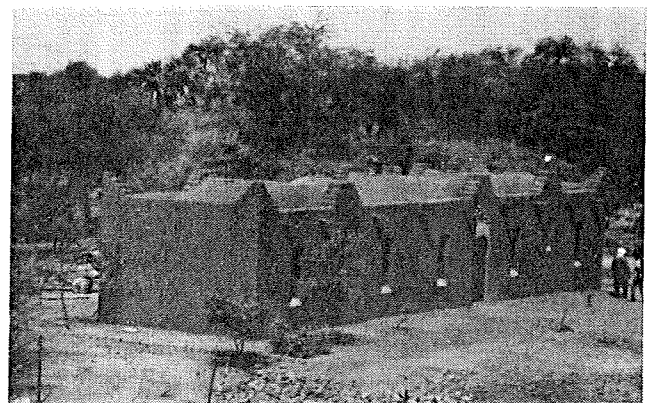

vault and dome communal housing (Catholic Mission, Tchirozerine, Niger).

with very widely differing functions.

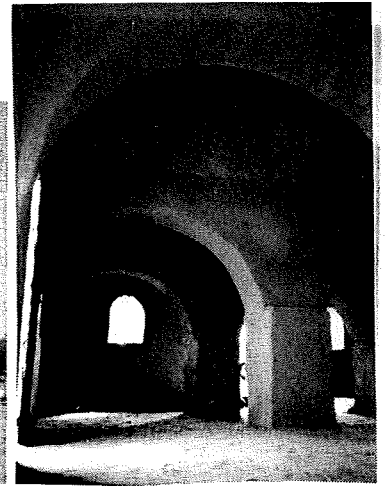

villagers in Bonkoukou (Niger) commissioned the design and building of their mosque from one of the few masons of the area trained in these techniques; in the background, unusual "traditional" mud brick vaults on a wooden supporting structure.



main hall of a purpose-built tourist centre. (Iférouane, Niger).

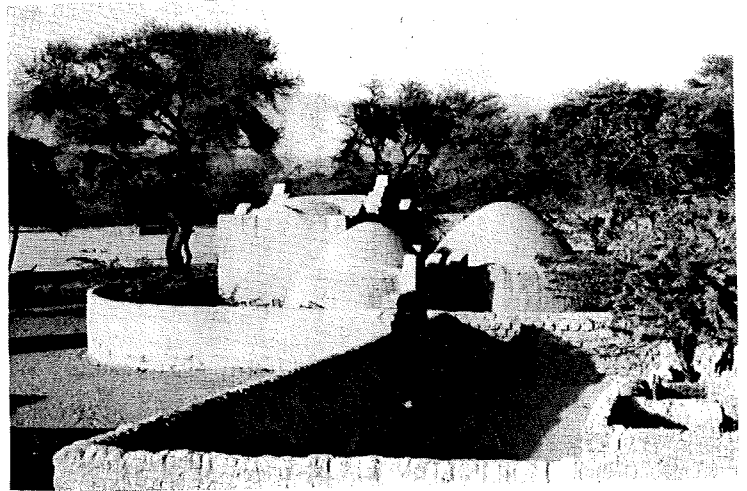

mason's self-built family compound: the full range of vaults and domes! (Iférouane, Niger.)



project infrastructure - office, private quarters, depot, and garage. (Iférouane, Niger).

Using unstabilized earth to build

What is stabilization? What is it for?

Stabilization is a process by which a soil is modified in order to permanently improve its performance. Most often (but not necessarily) it consists of:

- adding some other material (such as cement, lime, pozzolanic ash, bitumen etc.) which alters the way the soil behaves, and
- compacting it using a press (which could be manual, mechanical or motorized).

Stabilizing a soil inevitably means higher costs: the materials, the equipment, the the labour and expertise it requires cost money. Stabilization may result in a more durable building material in certain conditions, but given its cost, it makes sense to ask oneself the following questions before deciding to stabilize:

- does the soil available perform adequately for the building in question?
- if not, can any of the soil's deficiencies be overcome other than by stabilization, e.g. by modifying the design of the building?
- if not, can stabilization be restricted to the most exposed external surfaces?

The disadvantages of stabilization

- because of the additional costs of additives, press, and labour the vast majority of the developing world population cannot afford the blocks produced, which are often equivalent in price to that of cement blocks;
- as far as vaults and domes are concerned, using the wrong kind of render very often leads to serious problems of cracking and leaking; when stabilized earth is used, these are expensive and difficult to rectify;
- generally speaking, given their high cost, more attention must be paid to making the most economical use of stabilized blocks; this demands greater skill in design and construction and above all in technical site supervision, which is often lacking, leading to poor quality work and a bad image for earth buildings in general.

The advantages of using unstabilized earth

- production of unstabilized earth blocks is straightforward (only simple moulds are needed) and affordable - people very often make their own;
- because the blocks are cheap, thick walls can be built: these provide good insulation and are ideal in climates with a wide diurnal temperature range;
- a plain earth render is perfect for unstabilized earth walls and roofs: it adheres well and is cheap and easy to maintain, provided it is regularly and carefully checked.

How much do vaults and domes cost?

A pragmatic approach to evaluating building costs

To assess the cost of building vaults and domes in unstabilized mud bricks, we selected a range of buildings (including "traditional" buildings) and recorded their consumption of materials and labour as they were actually being built in Iférouane (Niger) in the late 1980's. The figures allow clear comparisons between the buildings. We can draw 5 broad conclusions which are set out on these pages.

Costs are in CFA francs per m² of usable surface area (SA) and are shown separately for the basic structure  and finishings . (\$ = 270 francs CFA)

1) A simple two-roomed house works out cheaper with a domed roof (on circular walls) or with a vaulted roof (on rectangular walls) than with a "traditional" flat roof using wood.

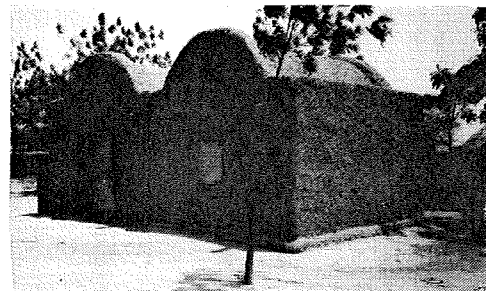
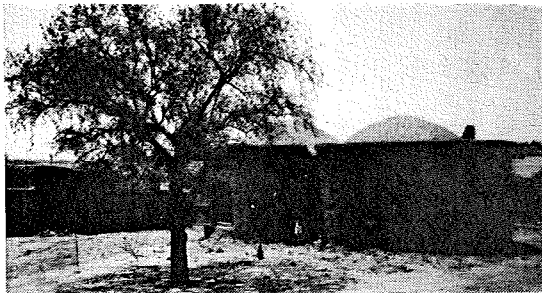

Even assuming the use of poor quality wood illegally obtained (i.e. without a permit) for the structure of the flat roof, vaults or domes remain a competitive alternative. And although slightly cheaper to build initially, the poor quality wood roof would need replacing at least every two years, if not annually: the small immediate cost advantage is therefore rapidly lost.

Cost in CFA francs/m² of SA of:

1. house with 2 round domed rooms; 40cm walls (30 m² SA)
2. house with 2 vaulted rectangular rooms; 40 and 60 cm walls (24m² SA)
3. "traditional" 2-roomed house with flat roof built using good quality wood - actual case (28m² SA)
4. "traditional" 2-roomed house with flat roof built using poor quality wood illegally obtained - assumed case (28m² SA)

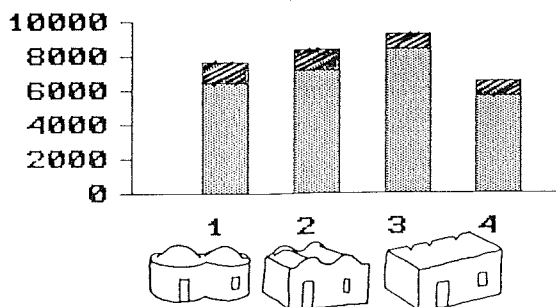

2) A "traditional" round straw hut can be replaced by a circular domed shelter at a comparable cost.

In many countries of the Sahel, "cases" are typically built by women and remain their property, but they are having to walk further and further to find the branches and grasses needed to build them. A simple, round domed structure with thin (20cm) walls capable of being built by women has evolved and costs only very slightly more. As the "case" does not last so long, over time, the domed shelter actually works out cheaper.



Cost in CFA francs/m² of SA of:

1. "traditional" round straw hut built entirely from organic materials (12 m² SA)
2. circular domed shelter, 20 cm walls (11m² SA)

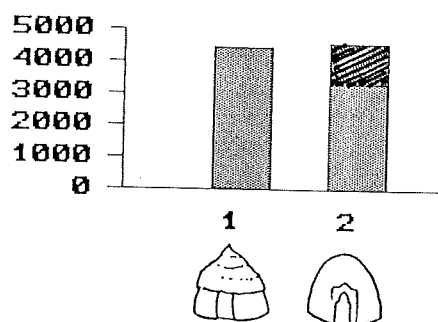

3) A dome on rectangular walls generally works out more expensive than a dome on round walls.

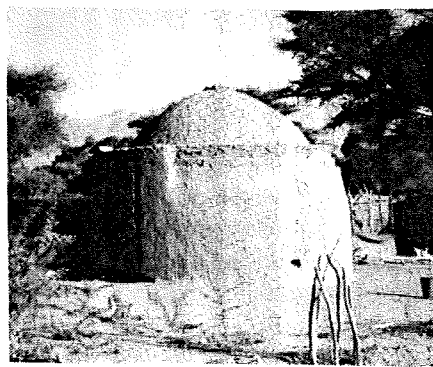
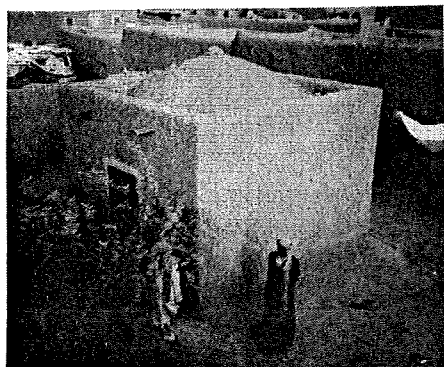

This additional cost can be attributed to the longer time needed to build domes on square walls (more complex layout, bonding etc.) and the less economical use of the building material. Nevertheless, for those who can afford it, rectangular rooms are seen as more practical and more "modern" and in some instances represent a status symbol for the owner.

Cost in CFA francs/m² of SA of:

1. round domed room; 40 cm walls (13m² SA)
2. square domed room; 40 cm walls (14m² SA)

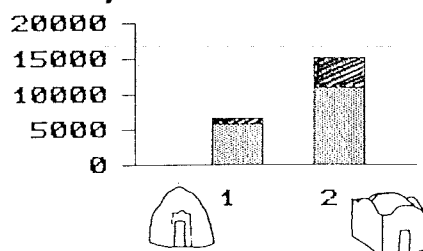

4) The cost of finishings can vary from 15% to 50% of the total cost.

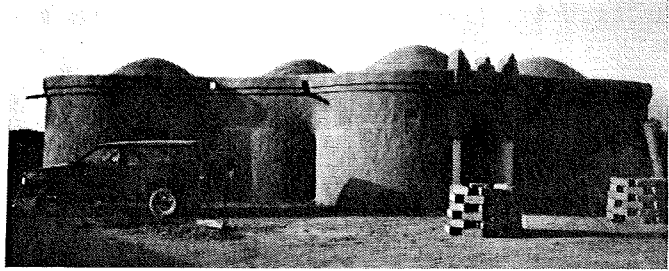
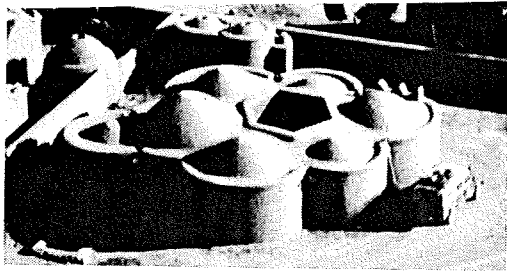

Relatively sophisticated buildings, such as the 2 private villas shown and quoted here, require a high standard of work and expensive finishings which account for up to 50% of the total cost of the buildings. This compares with 15 to 30% for the finishings of the other buildings shown on these pages and highlights the importance of comparing like with like.

Cost in CFA francs/m² of SA of:

1. Project house with 8 domed rooms and inner courtyard; 40 and 60 cm walls (89m² SA, excluding courtyard)
2. Private house commissioned from local mason by secondary school teacher; 8 domed rooms; 40 and 60 cm walls, (98m² SA)

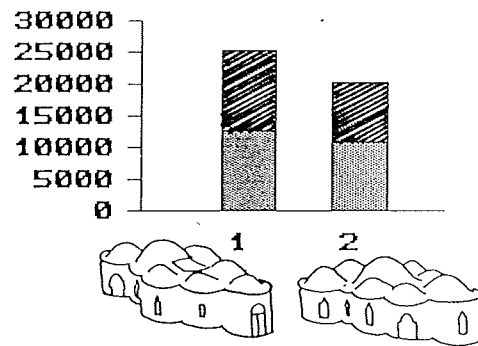

5) For small or medium-sized public buildings, vaults and domes provide an attractive local solution at a modest cost.

The Village Development Council of Iférouane (Niger) shown here, with a simple structure, but careful attention to detail, provides a good example of an attractive, comfortable public building at a modest cost.



Cost in CFA francs/m² of SA of:
Building with 3 round interlocking rooms; 40 and 60 cm walls (45m² SA)

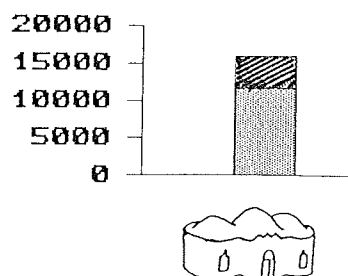

A few general observations on costs

Evaluating "real" costs is notoriously difficult. The following points should be borne in mind.

For "traditional" buildings -

- **many building activities are carried out in a spirit of mutual self-help, particularly in rural communities;**
- **building materials are often accumulated or prepared by the whole family over several months before actual construction can begin;**
- **it is difficult to place a fair financial equivalent on a product or on labour which may not be paid for in money, but which still represents a "cost" to the owner-builder (food for helpers, time taken out of income-generating activities to collect materials etc.)**

In this examples quoted on the preceding pages, to allow comparison between "traditional" buildings and others we included in the cost of the former an appropriate comparative value, agreed upon by local masons.

For any building -

- **the standard of work, the quality of materials used, and the nature of the finishings required - and therefore the cost of these - will vary enormously, even between apparently similar buildings;**
- **building groups and skilled masons need to include a profit margin, which will also vary widely, and which is often not easy to assess; in the figures quoted here, profits over and above wages paid are excluded;**
- **the future cost of maintenance of a building is often overlooked: vaults and domes need regular maintenance, but the cost of this remains low; wooden or straw structures, particularly if poor quality materials are used, will need totally replacing every few years and often much more frequently;**
- **when a building system is relatively new to an area and demand for it is high, the few masons trained can to some extent command "inflated" rates for their work; as more masons are trained and compete in the market, rates will tend to fall.**

Finally, the satisfaction of users' aspirations (comfort, hygiene, prestige, etc.) cannot be evaluated in financial terms. A simple, low-cost building may perform quite adequately against this important criterion; an expensive one, less well...

Vaults and domes - problems to avoid

Evaluating the quality of built examples

In 1990, Development Workshop visited nearly all of the 307 known buildings which had gone up in Niger and neighbouring Mali using unstabilized mud brick vaults and domes since this system had been introduced ten years earlier. Of these, nearly half (47%) had been built by trained masons working for themselves, their families, friends or clients (including state authorities, village organizations, etc.), without any external financial or technical assistance. The survey therefore provided an interesting opportunity to see what happens to the quality of building work using a "new" system as it begins to spread spontaneously and to identify any problem areas. The result was encouraging: of the 304 buildings surveyed:

- the vast majority - 297, or 98% - were in good condition, displayed no major structural problems, and were fulfilling their intended function;
- 5 had serious structural problems (totally or partially collapsed roofs);
- 2 were badly cracked.

Problem areas

The 7 unsound buildings displayed at least one of the following problems:

- inadequate (and in one case non-existent) foundations;
- bad wall-building practices, particularly poor bonding;
- dome courses built up too rapidly, causing it to sag and push out the walls;
- insufficient attention to rapid rainwater runoff (e.g. blocked spouts);
- wrong renders (badly prepared or applied earth renders, or cement renders).

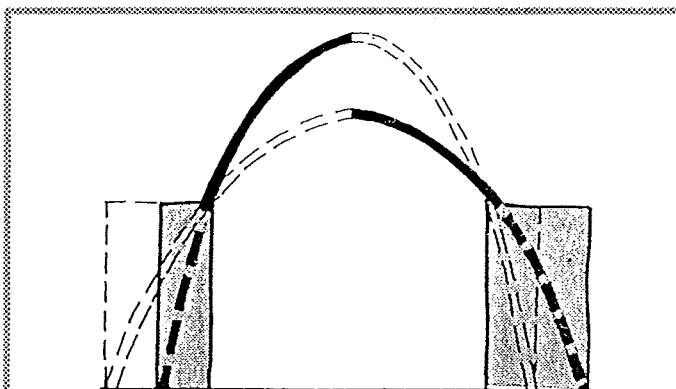

The width of the supporting walls varies with the height and span of the vault: the walls must be thick enough to withstand the lateral force exerted by the vault. This also applies to domes.

Only in 2 cases did we find a problem related specifically to the design of vault and dome buildings:

- walls insufficiently thick to withstand the lateral forces exerted by the vault or dome.

Underlying causes of problem areas

- insufficient or incomplete training, leading to poor work practices;
- misguided pressure for faster work (e.g. time must be allowed between building dome courses) or to economize on materials (e.g. insufficiently thick walls).

Woodless construction must therefore include formal training, including on-the-job experience, and post-training assistance and quality control.

A few basic rules....

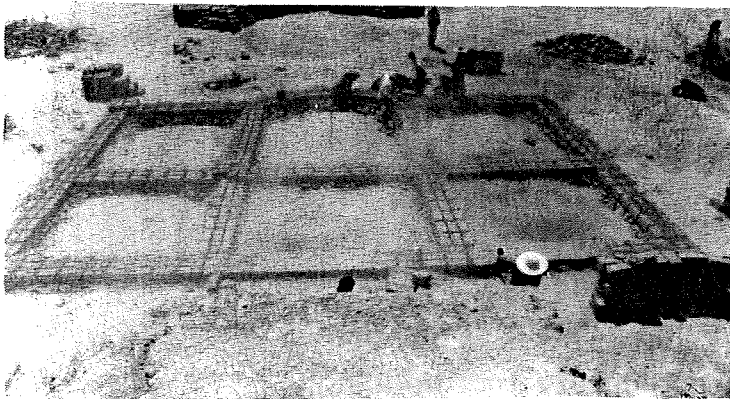

Careful bonding, on good foundations...

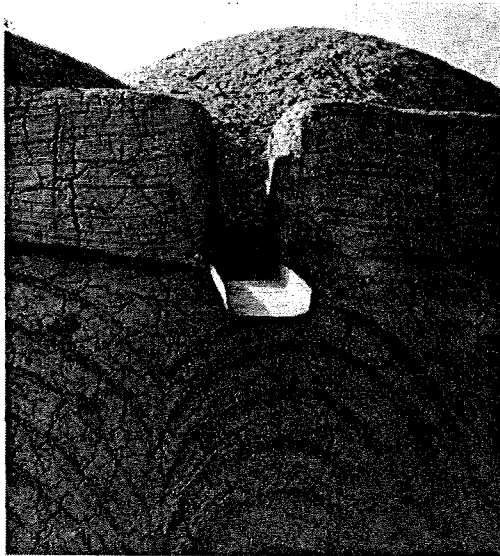

*Ensuring fast rainwater runoff;
using a suitable render and
maintaining it regularly...*

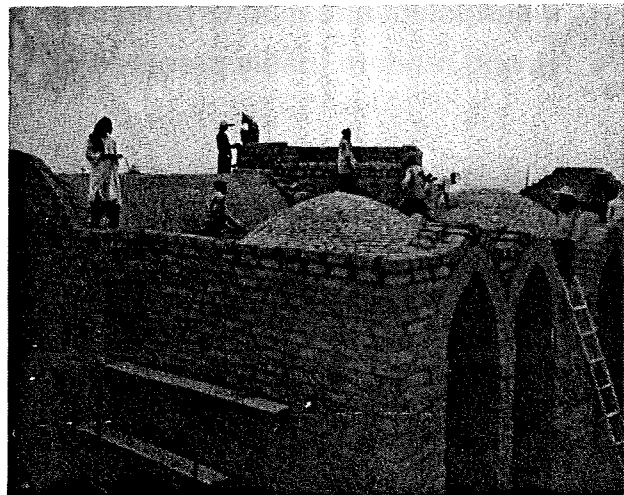

Adequate site supervision and quality control ...

Will vaults and domes suit your area?

Careful thought is needed before deciding to build vaults and domes using unstabilized mud bricks. As with any building system, you have to be confident that it stands a real chance of suiting local conditions and matching the needs and aspirations of the people. Certain criteria need to be taken into account, including the climate, the resources available, and the lifestyle of the end-users.

Climate

It is a common misconception that unstabilized mud brick vaults and domes can be built only in the most arid regions of the world. In fact, correctly designed and built, they stand up well to more varied climates. The "coil" construction granaries, with thin (3 cm) mud walls, found throughout the Sahel, testify to the durability of these unstabilized earth structures and to the wealth of local knowledge on how to build and maintain them. The photograph on the right was taken in southern Niger, where annual rainfall is in the order of 400 mm p.a. and often falls in very violent showers. Similar examples are found in regions with annual rainfall figures around 500 mm.

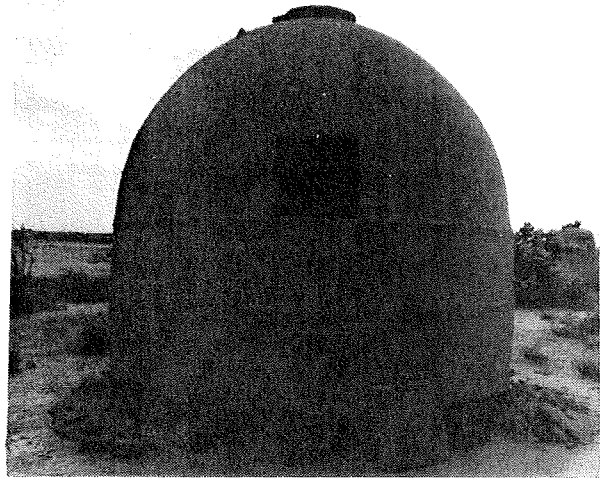

"Coil" construction granary typical of many regions of the Sahel, with thin unstabilized earth walls. Local knowledge of how to ensure that such buildings resist heavy downpours of rain exists...

To take an example from our own experience, in 1983 we built two vaulted buildings in unstabilized earth in Filingué (Niger), where the annual rainfall is 350 mm p.a. The buildings (shown below) were finished with an earth render and for 7 years received no maintenance. In 1990, they were given a new earth render, (cheap and easy), but structurally were found to be perfectly sound.

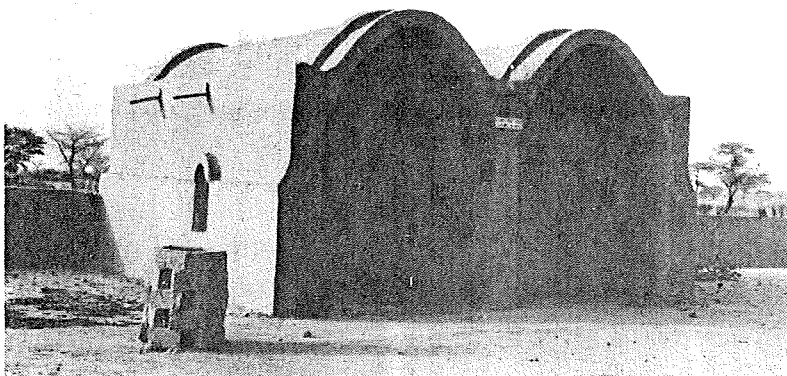

Such examples are encouraging, but it must be stressed that correct design, good building skills and careful and regular maintenance of the surface render are essential.

Unstabilized mud brick vaults with an earth render: after 7 years of no maintenance, structurally sound and requiring only re-rendering.

Correct design and good building practices

Rain as such poses few problems for roofs or walls built from suitable unstabilized earth, but it is vital to ensure that rainwater drains away from the building rapidly. For example:

- the site chosen for the building should not be liable to flooding (a slight slope is ideal from this point of view);
- footings and foundations should be built in such a way as to prevent rainwater from collecting at the base of the walls;
- roofs must be designed to ensure rapid rainwater run-off (see photo below)-
 - a hand-compacted earth infill can be used to create or accentuate slopes;
 - spouts (sufficiently wide to avoid being blocked) prevent water from running down the walls;
 - parapets or other decorative elements can be used to channel water.

Rendering

The true function of an external render is not to prevent water from penetrating the building (which is watertight as soon as it is structurally complete). The render protects the structural elements (blocks and mortar) from erosion and presents a surface which is easier to maintain.

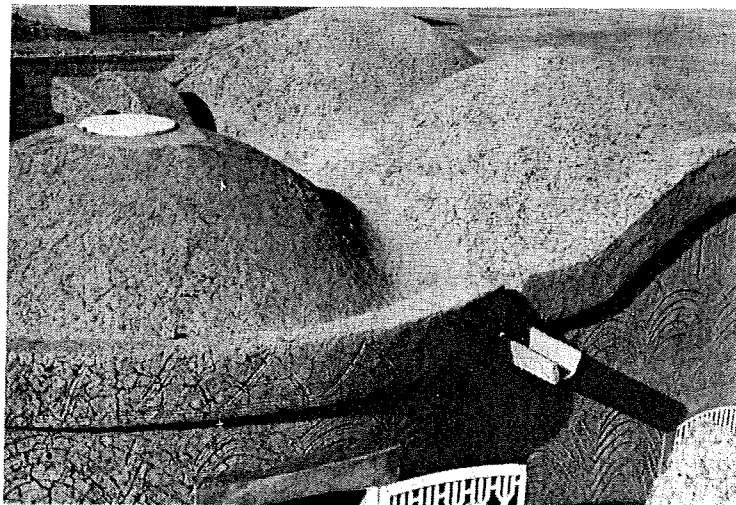

Above all, the render must not crack and become unstuck, as this enables water to penetrate and be retained in the gap between the structure and the render, causing serious damage which may be very difficult and expensive to put right.

It is therefore vital to:

- use only materials (e.g. traditional earth renders) which adhere to earth walls without cracking or becoming unstuck; (avoid cement, or soil-cement renders: these may erode slowly, but they adhere badly to earth surfaces);
- check the state of the render regularly: at least once a year and after heavy rainstorms;
- carry out routine maintenance - regularly done, maintaining a correct render is cheap and easy.

Resources

Suitable soil

Are earth buildings common in the area? Are they in good condition? Do the local inhabitants regard them with pride? Are they happy to live in them? If the answer to such questions is "yes", it is highly probable that the local soil is suited to building with earth.

There are also simple field tests which can help you to decide if the local soil is suitable, but local knowledge is often an invaluable guide. Local masons can tell you where they obtain their soil for block-making and whether they add anything to it. What they can tell you can often be a short-cut to deciding whether you need to test at all, and if so for what.

Equipment

The equipment needed can be very simple or relatively sophisticated.

For producing blocks, you need only:

- ordinary tools for digging;
- simple or multiple hand-moulds.

For construction work:

- common masonry tools;
- a water-level for levelling foundations;
- a plumb-line;
- for dome-building, a wire or string, or a rotating arm, to determine the angle and position of each brick;
- for vault-building, wire or string to trace the curve of the vault and to stretch guidelines during construction;
- scaffolding.

You might also choose to use:

- wooden or metal formworks to build various forms of arch.

suitable soil...

*... and very simple
or more specialized
equipment...*

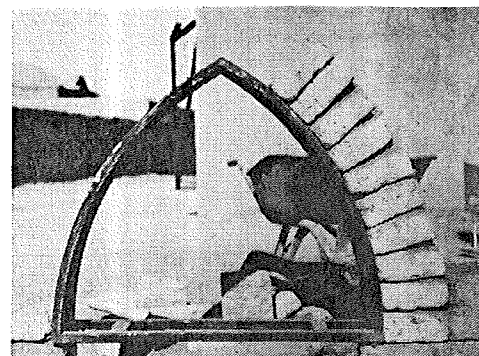
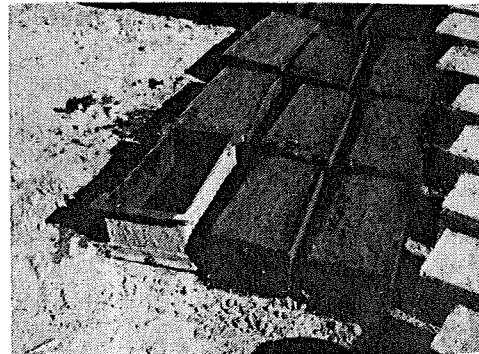
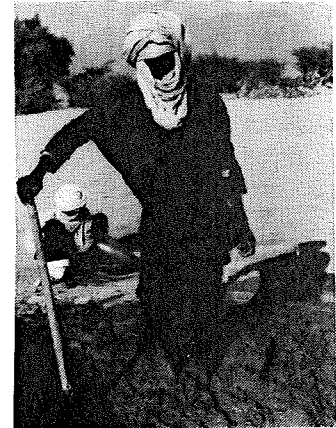

Lifestyle

No building system - however technically "appropriate" - will be assimilated into the local vernacular tradition unless it readily responds to people's needs and aspirations. As far as vaults and domes built in unstabilized mud bricks are concerned, our experience over 12 years in the Sahel suggests that:

- most people find domes and vaults intrinsically attractive and they have proved flexible enough to adapt to local architectural idioms;
- vault and dome buildings provide varying levels of climatic comfort and cleanliness, largely depending on the finishings used, but usually compare favourably with other local or "modern" building styles in this respect;
- costs (see sheet E) do not present an obstacle: often the basic material (unstabilized mud blocks) can be obtained much more easily than "traditional" organic materials.

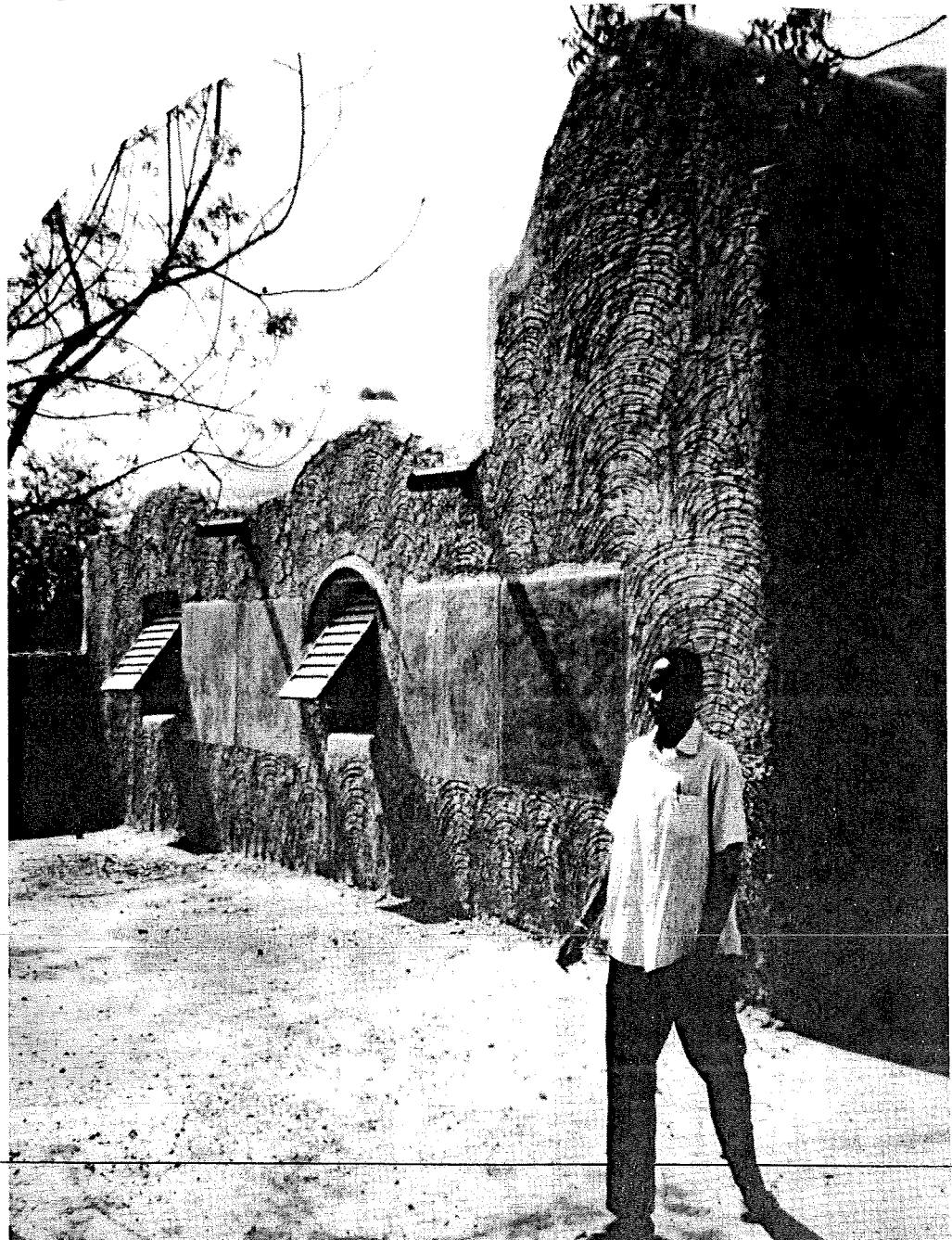

Introducing vaults & domes to your area

There are no "rules" about how to introduce woodless construction to a new area, except perhaps "slowly and cautiously, if at all". Introduce this building system only in areas and circumstances where it stands a real chance of being assimilated and replicated - of continuing to be used and to evolve when technical and financial support is over.

The notes below might help you to focus on important questions and perhaps to structure an approach. The case study overleaf illustrates some of these key issues and one approach which - after a slow start - seems to have worked.

What is the "problem" you are trying to address?

Make sure that the "problem" - both as you see it and as others express it - is truly one which should be addressed by constructing a building.

For example, you might be able to make better use of limited funds by building a good road to reach an existing hospital, than by building a new clinic in the village.

Does woodless construction have a role to play?

Woodless construction has a particularly useful role to play where (1) local building systems tend to rely heavily on the use of wood and (2) usable wood is becoming significantly more difficult or expensive to obtain.

It may not be particularly useful if only one of these factors exists - or is perceived to exist.

Is it technically viable?

Factors to take into account include the nature of the soil and the climate. (See section G).

At least as important, however, is the building process: are mud blocks made locally to the required size and quality? do most people use skilled masons to build at least part of their home? etc.

Will people be able to afford to build this way?

Evaluating costs is not easy, but there must be at least a reasonable chance that people will be able to afford a new way of building. A comparison with the cost of building the "usual" way is essential. (See section E for examples).

If it is likely to cost more, can people afford the extra cost? will they think that it is worth it?

Will they like domes and vaults?

People have clear images of what the buildings they use should look like. Vaults and/or domes might be linked with a particular function or image. In some areas, round houses, even with a "new-style" dome, are regarded as old-fashioned.

Putting up a small building and giving people time to react to it may be very useful.

The house that Mounkaila built - a case study

Ouallam is a district capital some 100 kms north of Niamey, Niger. With a population of 5,000, it is the centre for numerous scattered Zarma villages. Recent rains have been lower than the map suggests, averaging 350 mm p.a. during the 80's, and this, together with population growth, has contributed to a rapid deterioration in the surrounding vegetation. One consequence of this deterioration is that the organic materials used for the flat roofs of traditional houses are increasingly difficult to obtain, whether by gathering or purchasing.

Initial training: project "push"

In 1987, Ouallam was selected as a pilot centre for the African Food Systems Initiative (AFSI), a US Peace Corps programme funded by USAID. AFSI operates through teams of 5 to 10 volunteers working in the same district over a 10-year period. In their 2nd year of operation, the volunteers needed to build a hostel, but wanted to find a way to do this without using scarce and over-exploited wood. They had heard of the vaults and domes being built in other areas and selected 4 local masons to go on a training course being run in Iférouane, a considerable distance away.

The masons, it was hoped, would return to build the hostel using their new skills; the hostel would serve as an example of how to build without wood; local people would be convinced and want to build this way for themselves and the village would have its own trained masons to meet this demand.

The reality was rather different.

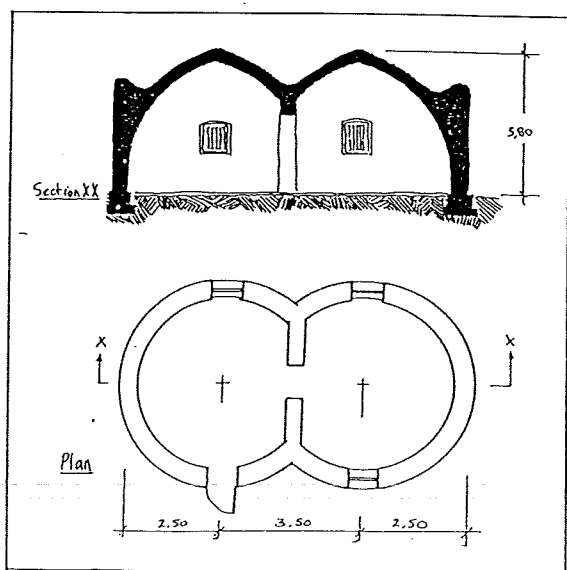
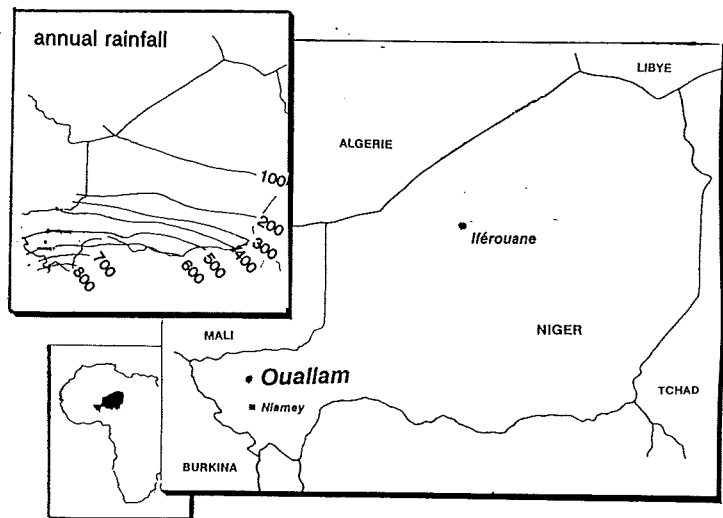

1st project-funded demonstration - technically sound, but economically and socially unconvincing

The masons did build the hostel, after many delays and at a cost which, by village standards - though not by most project standards - was exorbitant, mainly because of inflated labour and transport rates. Nevertheless, although simple, it proved a strong and comfortable building which withstood the intermittent, but often violent rains of the Sahel well. But 2 years later, no other houses had been built in this way and the masons were beginning to lose confidence in their ability to remember what they had learnt. The AFSI volunteers continued to discuss building without wood when the opportunity arose, but there was little real enthusiasm. This was in part because the hostel was designed as two interlocking circular rooms, simple to build and structurally extremely stable. Local people's idea of a "modern" house, however, was one with rectangular rooms.

Meanwhile, Development Workshop kept in touch. Peter Tunley, DW Associate, had trained the 4 Ouallam masons in Iférouane whilst working for an IUCN/WWF project for the conservation of natural resources. He invited one of the AFSI volunteers, Cindy Bullard, to visit Iférouane to see other "woodless" buildings and talk to the masons there who were using the building system, unaided, for themselves and their clients. She returned full of enthusiasm, and organized a 3-day tour for two of the Ouallam trained masons, Mounkaila and Souley. Together they visited other buildings in villages north of Ouallam and - most important - talked to other masons who were using the techniques regularly. Mounkaila and Souley were particularly keen to quiz their hosts about building rectangular domed houses, which they had not done on their course.

2nd self-funded demonstration - the house that Mounkaila built

The short tour proved to be a turning point. 2 days after they returned, on their own initiative, the two friends set about building a two-room domed house for Mounkaila - but this time with rectangular walls. With a team of 5 men, the house was finished in 14 work days (after brick-making) at a daily cost of only 225 Fcfa (4.5 French francs or 80 US cents) for giving cola nuts and cigarettes to the helpers. The result was a sound domed house finished to village standards.

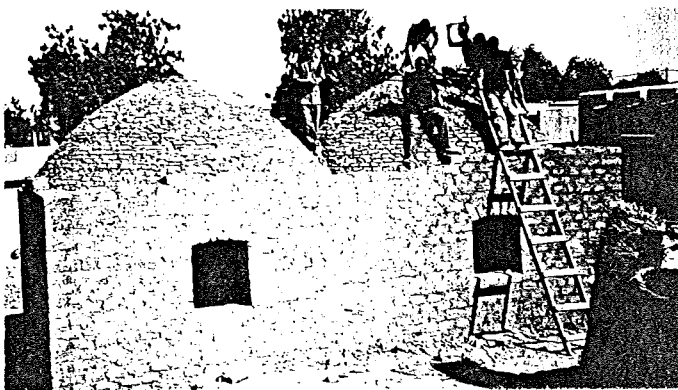

Word spread rapidly. Within a month people from neighbouring villages were dropping by to see the rumoured "house with no wood". Mounkaila was famous! Government forestry workers visited his home to see its relevance to their work. AFSI volunteers were approached by more masons asking where they could learn. AFSI agreed to fund a training course in Ouallam itself, but only when they had first carried out a careful survey to make sure of both the personal motivation of the masons and the genuine commitment of the village leaders. Thus each mason agreed to

donate his labour after training to build one building in his home village and the village leaders undertook to find a suitable opportunity, and to provide a site and materials, for this to happen.

A tailor-made course: village "pull"

16 masons from Ouallam and neighbouring villages (and 4 from further afield) attended the one-month course, designed and run by Development Workshop in late 1991.

The training itself was carried out by 4 experienced masons from other areas of Niger. It combined theoretical sessions and practice building with the "start-to-finish" construction of 6 public buildings.

These had been selected with the help of the district government services, who had only to provide finishings (doors, windows, etc.) after the course was over.

All 6 were structurally complete by the end of the course: a bus/taxi station; a school library; a medical ward; an office; a cooperative store and a depot.

The trainees and the villages were as good as their word. A fortnight after the end of the course, four further buildings were well underway in four separate villages; a good number of the masons were planning to build their own houses; and several villagers were amassing mud bricks in readiness for hiring the masons.

Luck played its part in this surge of enthusiasm: there had been a good rainy season and an excellent harvest: the men were able to stay in the region and build rather than be forced further afield to find work.

At the time of writing (June 1992), AFSI volunteers report that woodless construction is continuing to spread in the Ouallam district. And that Mounkaila is still nicknamed "the-man-who-built-his-house-without-wood"...



The Ouallam experience → Some tentative guidelines

In Ouallam, the first training exercise (sending 4 masons to Iférouane) did not result immediately in any spontaneous building activity, even after a technically sound building had gone up in the village and been seen to perform well.

A technically viable solution to a genuine problem, and the capacity to provide it (e.g. trained masons) does not in itself generate demand for that solution.

The initial project-funded demonstration building (the AFSI hostel), although built to a design which did not prove very attractive to local people, nevertheless established the technical viability of the building system in this new area.

Limited external funds can be used for a simple demonstration building. This absorbs the financial risk involved in trying out something new and enables the performance of the building - and people's reactions to it - to be observed over time (e.g. through a rainy season), before major funds and efforts are committed.

The masons' visit to other areas with experienced masons working regularly with woodless construction proved a turning point.

The opportunity to inspect built examples and talk with other masons is invaluable.

The second self-funded "demonstration" building (Mounkaila's house), made significantly more impact, partly because it matched people's aspirations (rectangular walls), but mainly because it was built using friends to help and finished to village standards.

Form is often as important as function. A demonstration should be seen to be within people's reach and to match their aspirations.

Unlike the first training experience (sending 4 masons to Iférouane), the 2nd (the Ouallam training course, including 6 buildings) was followed by a great deal of building activity.

Personal motivation and public commitment should be established before training.

A range of built examples with different functions, and of varying size and shape, helps to show the possibilities of the techniques.

Structured "on-the-job" training, combined with formal teaching of the principles, is both efficient and generates confidence and pride amongst the trainees.

Without the long-term presence of development workers it is unlikely that woodless construction would have ever come to Ouallam.

A flexible, careful approach, carried out in stages, may seem slow, but is more likely to yield results than a "force-fed" pace.

For further information and help...

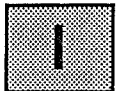

Publications and video-cassette

Development Workshop has prepared a range of publications and produced a short video-cassette on various aspects of Woodless Construction, with funding from IUCN (The World Conservation Union). At present, these are available only in French, but many are heavily illustrated with photographs and diagrams and may still be of interest even if French is not your working language.

This sheet can be detached or photocopied and used as an order form - see over.

Requests for free copies of documents from genuine cases will be treated sympathetically. Please write explaining your situation and interest.

Contact us direct

Development Workshop would be pleased to hear from individuals and organizations who have read this document and who have an interest in woodless construction. Please send your comments, questions, or observations from your own experience to John Norton or Peter Tunley at the address below.

Development Workshop,
B.P. 13,
82110 Lauzerte,
France.

tel. (33) 63 95 82 34

fax. (33) 63 95 82 42

Name:

Organization:

Address:

.....

.....

.....

tel.:.....fax:.....

I wish to order the following and I enclose payment by cheque or international money order in French francs payable to Development Workshop. (Prices include postage and packing.)

Signed: date:

	quantity	price	total
<i>Guide Pratique: Les Toitures sans Bois</i> Development Workshop, 1990, revised 1991, 77 pages.		85 FF	
<i>Une méthode de communication aux maçons.</i> <i>Fiches techniques et dessins</i> Development Workshop, 1991, 25 pages.		30 FF	
<i>Iférouane - habitat en évolution</i> Diana Hammer & Peter Tunley, with Development Workshop, 1991, 30 pages.		35 FF	
<i>Etude Economique: Bâtiments en adobe, Niger</i> Peter Tunley, Development Workshop, 1991, 31 pages.		35 FF	
<i>Etude Technique: Bâtiments en adobe, Niger</i> Alexandre Douline, Development Workshop, 1991, 106 pages.		110 FF	
<i>Vulgarisation de la construction de voûtes et coupoles au Sahel: L'identification des besoins</i> Development Workshop, (IUCN mission report) 1990, 59 pages		65 FF	
<i>Programme Habitat Humain: Evaluation des bâtiments et des techniques de construction, Cercle de Youvarou, région de Mopti, Mali</i> Development Workshop, (IUCN mission report) 1991, 45 pages		50 FF	
video-cassette: LA CONSTRUCTION SANS BOIS, Development Workshop and IUCN, 1992, 19 mins, PAL/SECAM		300 FF	

please specify : PAL / SECAM

TOTAL (payment enclosed with order)